



UK and Ireland distributor

WINLET 375

Dual Circuit Window & Glass Installation Robot

Maximum Capacity - Minimum Space

The **Winlet 375** combines superior lifting capacity and reach with a unique and compact design coupled with its low weight makes it ideal in almost any construction environment



Wired remote control



375kg

360° rotation

45° back / 97° Forth tilt

Technical specification

Max. working height	3,078mm
Max. extension from front bumper to suction cup	958mm
Extension capacity at max extension	200kg
Side lift capacity	200kg
Linear	200mm
Fine lift on jib head	100mm
Suction cups (Glass)	4 @ 310mm Ø
Total machine weight	732kg
Power source	Battery 110v on-board charger
Remote control	Wired

Features include



Operator-friendly design and integrated buttons make the multi-function control panel easy to use. Signal lights and double-action safety keys are included in the standard Winlet 375 set-up.

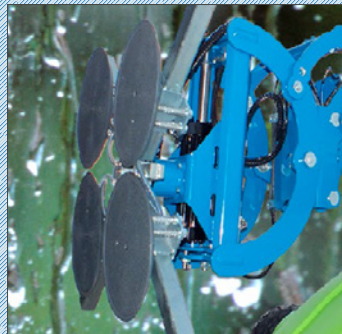

All equipment panels are water jet resistant and dust tight to IP65 rating standard.



Vacuum Robots Course



Northern
01482 227333

Central
01302 341659

Western
01384 900388

Southern
0203 174 0658



The Winlet 375 glazing robot minimises manual handling to maximise safety and productivity.

Dimensions (mm)

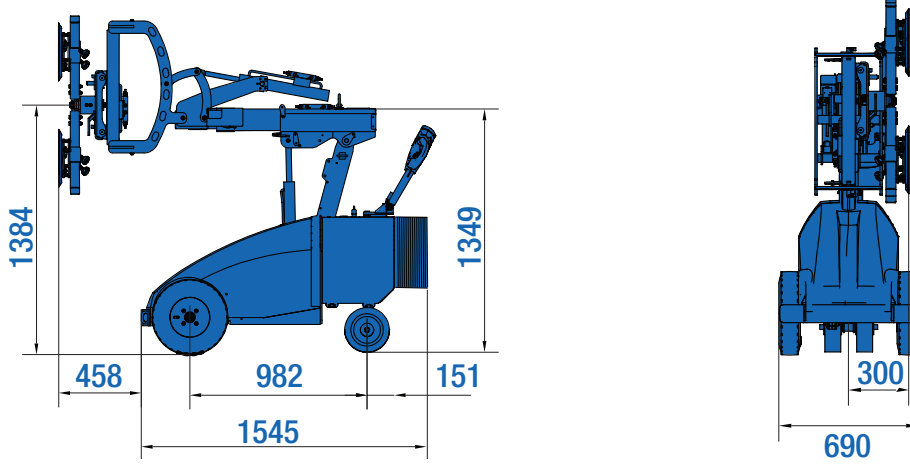

Pick and place

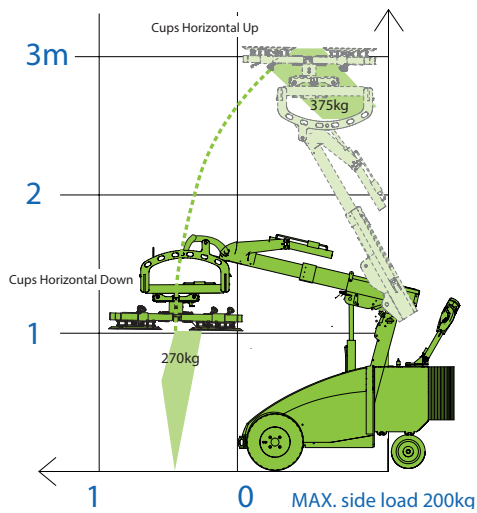

Reach

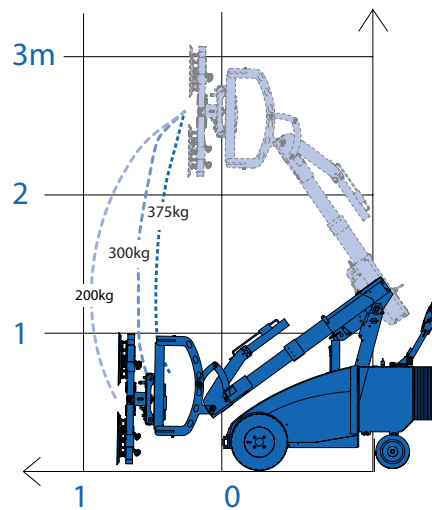

Product specifications are subject to change without notice or obligation. The photographs and/or drawings in this document are for illustrative purposes only.