

Instructions for the safe use of: Wire Rope Lashings

The information in this leaflet should be passed to the user of the equipment

This document is issued in accordance with the requirements of Section 6 of the Health and Safety at Work etc Act 1974, amended March 1988.

This information is of a general nature only covering the main points for the safe use of Wire Rope Lashings. It may be necessary to supplement this information for specific applications. See also the general guidance on load restraint, given overleaf.

ALWAYS:

- Inspect wire rope lashings before use.
- Calculate the lashing force(s) required for the chosen method of load restraint.
- Select the capacity and number of wire rope lashings to provide at least the calculated lashing force(s)
- Ensure the lashing points on the vehicle and/or load are of adequate strength.
- Protect the wire rope lashing from small radii. A minimum radius of 4 x rope diameter is required to avoid kinking.
- Ensure the wire rope lashings are correctly tensioned.
- Exercise care when releasing wire rope lashings in case the load has become unstable since the lashings were applied.

NEVER:

- Use wire rope lashings to lift a load.
- Knot, tie or modify wire rope lashings.
- Overload wire rope lashings.
- Use wire rope lashings over a sharp edge without edge protection.
- Expose wire rope lashings to chemicals without consulting the supplier.
- Use wire rope lashings which have any kinks or broken wires, or damage to the tensioner, ferrule terminations or terminal fittings or missing ID tag.

Selecting the Correct Wire Rope Lashing

The standard for wire rope lashings is BS EN 12195-4: 2003. It requires the wire rope to be of 6-strand ordinary lay with fibre or steel core with a minimum of 114 wires or of 8-strand ordinary lay with steel core with a minimum of 152 wires, as given in EN 12385-4. Only stranded steel wire ropes of the grade 1770 shall be used.

The connecting components to conform to EN 1677-1, 2 or 4 as appropriate. Connecting and shortening components must have a securing device such as a safety latch.

Wire rope lashings are available in a range of capacities and lengths and in various configurations. Some are general purpose. Others are intended for specific applications.

Selection should start with an assessment of the forces acting on the load. The lashing force(s) required should be calculated in accordance with BS EN 12195-1: 2010.

Next check whether the lashing points on the vehicle and/or load are of adequate strength. If necessary apply a greater number of lashings to spread the force across more lashing points.

Wire rope lashings are marked with their lashing capacity (LC). expressed in daN (deca Newton = 10 Newtons) This is a force approximately equivalent to a weight of 1kg.

Using Wire Rope Lashings Safely

Ensure that the tensioner is free to align and not bent over an edge. Ensure that the wire rope is not knotted and that the terminal fittings engage correctly with the lashing points.

Ensure that the wire rope is protected from sharp and small radius edges by suitable packing or edge protectors.

In-service Inspection and Storage

Wire rope lashings can be damaged by tensioning them across small radius edges without adequate edge protection. However damage may occur accidentally as a result of the load moving in transit hence the need to inspect before each use.

Wire rope lashings should not be exposed to chemicals. If accidental contamination occurs, the lashings should be cleaned with clear water and allowed to dry naturally. Weak chemical solutions will become increasingly stronger by evaporation.

Wire rope lashings should be inspected for obvious signs of damage before each use. Do not use the wire rope lashing if any of the following defects are found: illegible markings; visible wire breaks of more than 4 on a length of 3 rope diameters, more than 6 on a length of 6 diameters or more than 16 on a 30 diameter length; wear or abrasion of the rope by more than 10% of the nominal diameter; crushing of the rope by more than 15%; kinks; damage of a ferrule or a splice; distorted or notched coupling components or end fittings; ineffective or missing safety latches.

Wire rope lashings will gradually wear over time. The LEEA recommends that they should be inspected by a competent person at least every 6 months and a record made of the result.

Wire rope lashings should only be repaired by someone competent to do so.

For long term storage the storage area should be dry, clean and free of any contaminants.

© Lifting Equipment Engineers Association 2012 SI No. 24.0

Further information is given in:

BS EN 12195-1: 2010 Load restraining on road vehicles – Safety - Part 1: Calculation of securing forces

BS EN 12195-4: 2003 Load restraining on road vehicles – Safety - Part 3: Lashing steel wire ropes

European Best Practice Guidelines on Cargo Securing for Road Transport

Department for Transport code of practice – Safety of Loads on Vehicles.

LIFTING EQUIPMENT ENGINEERS ASSOCIATION



Full Member

3 Osprey Court, Kingfisher Way,
Hinchingsbrooke Business Park, Huntingdon
Cambridgeshire, PE29 6FN United Kingdom
Tel: + 44 (0) 1480 432801
Fax: + 44 (0) 1480 436314
E-mail: mail@leaa.co.uk
Website: www.leeaaint.com

Hird Lifting Ltd,

Unit 8, Redhill 23 Business Park,
Holmethorpe Avenue, Redhill, Surrey RH1 2NB

Tel: +44 (0)203 174 2551 Fax: +44 (0)1737 773188

Email: london@hird.co.uk

General Guidance on Load Restraint

This information is of a general nature only covering the main principles of load restraint.

Terminology

Load restraint is a general term covering all three methods of securing loads to vehicles. Without restraint a load is very likely to slide or topple in transit. The three methods are:

Blocking

Blocking is a securing method where the load lies against fixed structures or fixtures on the vehicle such as headboards, sideboards, stanchions or bracing which prevents the load from sliding or toppling.

Lashing

Lashing is a securing method which uses flexible lashing equipment to tie the load to the vehicle. There are two main types of lashing, frictional lashing (also known as top-over' lashing) and direct lashing.

Frictional lashing forces the load onto the bed of the vehicle so as to increase the friction between the load and the vehicle bed. See figure 1.

Direct lashing connects a load bearing attachment point on the load to a lashing point on the vehicle. See figure 2.

Many lashing systems are a combination of direct and frictional lashing. Lashing can be used in conjunction with blocking.

Locking

Locking is a securing method where the load is secured to the vehicle by mechanical devices such as the twist locks which secure freight containers.

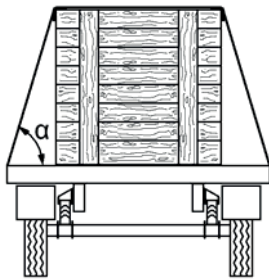

Figure 1
Example of frictional lashing

Figure 1 illustrates a wooden crate secured by a friction lashing. It is the vertical component of the tension in the lashing which forces the crate onto the bed of the vehicle. The maximum friction is obtained when $\alpha = 90^\circ$. When α reduces, the friction reduces. For example, when α is 30° , the effect is halved. The amount of friction also depends upon the friction factors of the materials the load and the bed are made from. (See Annex B of BS EN 12195-1 for a table of friction factors.) It can be enhanced by using a friction mat between the load and the bed.

Figure 2 illustrates a dumper truck secured by direct lashing. With direct lashing it is the horizontal component of the tension in the lashing which provides the majority of the longitudinal and transverse restraint. This horizontal component of the tension increases as α decreases.

Whilst the vertical component does increase the friction, the contribution of the friction to the overall restraint is relatively small. In plan view, the longitudinal lashing angle β_x controls the balance between the longitudinal and transverse restraint. For a given lashing capacity and vertical lashing angle α , as β_x increases, the longitudinal restraint decreases and the transverse restraint increases.

Direct lashing can only be used when both the load and the bed have lashing points compatible with the required strength of the lashing.

Other methods of lashing are loop lashing, spring lashing and round turn lashing. These are often used in conjunction with blocking. The European Best Practice Guidelines illustrates all these methods and explains them in more detail.

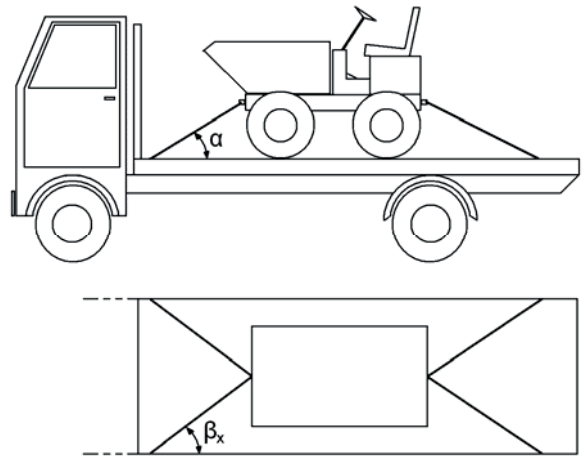

Figure 2
Example of direct lashing

Forces acting on the load

Loads on road vehicles are subjected to the forces generated due to the vehicle accelerating, braking and cornering.

EN 12195-1 specifies how the lashing forces should be calculated based on the possible acceleration of the load. The acceleration is expressed as a coefficient which, in effect, is the proportion of the weight of the load which the lashing must restrain in a particular direction.

Figure 3 illustrates the forces which can arise from the acceleration, braking and cornering of an HGV under normal driving conditions. For example, under braking the load can push forward with a force equivalent to 0.8 of the weight of the load.

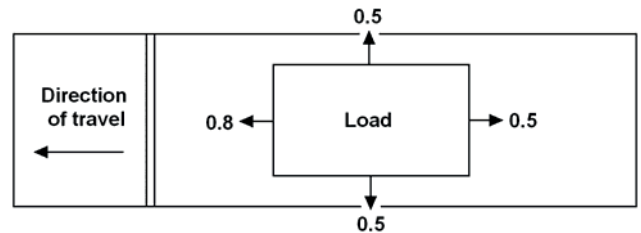

Figure 3
Forces acting on the load

As well as trying to make the load slide, these forces may try to topple the load. Additional restraint may therefore be required to prevent the load from toppling.

Lighter vehicles generally can accelerate, brake and corner more sharply than those classed as an HGV. Therefore higher forces may act on the load if the gross vehicle weight is less than 3,500kg. Higher forces may also act on the load if the vehicle is transported by rail or sea.

Other considerations

The standards and guidance assume that the bed of the vehicle is equipped with suitable lashing points. Unfortunately this is not always true. It may be possible to achieve adequate restraint by using a greater number of lashings thus sharing the load across more lashing points. However it must be shared equally taking account of possible movement in transit.

Lashing equipment used without protection over the edges of a load can result in the load damaging the lashing equipment. The degree of risk varies with the type of lashing equipment. See the specific guidance overleaf.

Periodically checking the lashing equipment for security and tension during a journey is recommended.

Fixing and releasing load lashings often involves working at height or alongside the vehicle at the roadside, both of which can be hazardous. Users should consider the risks involved and address them when planning the method of load restraint.