



GML800 Manual

Counterbalance Floor Crane

www.hird.co.uk

This cutting edge counterbalance material lift has a 800kg capacity lifting up to 4.98m. Extending forks or crane boom come as standard.

- Manual Winch or 3-Step Drill Kit as standard for easy operation (socket & drill not included)
- Extending Crane Boom (SWL reduces upon extension)
- Extending Forks (SWL reduces upon extension)
- Dual Safety Brakes in the masts
- Compact working & transportation positions
- Low 5cm loading height



800kg

Technical Specification

Capacity	800kg
Working Height	4.98m
Width	780mm
Length (working)	1,900mm
Weight dead weight - lift only	260kg
inc. counterweights	467kg
Power	Manual

Dimensions (mm)

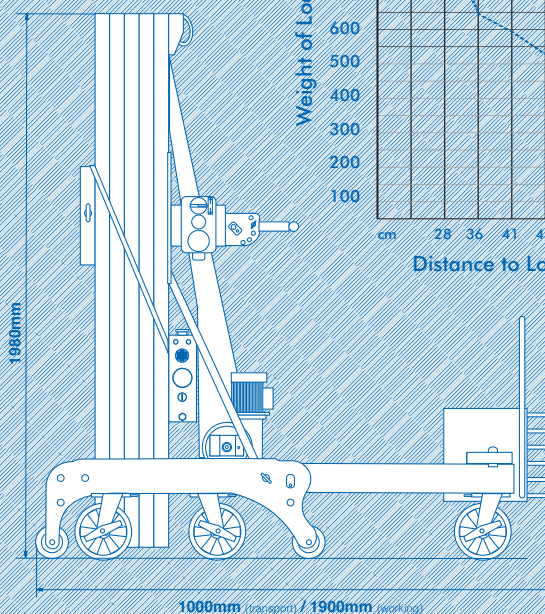

LEEA - Counterbalance floor crane



Product specifications are subject to change without notice or obligation. The photographs and/or drawings in this document are for illustrative purposes only.

Northern
01482 227333

Central
01302 341659

Western
01384 900388

Southern
0203 174 0658