

MRT4

Dual Circuit Vacuum Lifter

The Woods Powr-Grip MRT4 is another of Hird's popular vacuum lifters. Offering multiple configurations and a 'short-arm' option, the MRT4 is a great choice for most load sizes.

- Powerful 320kg lifting capacity
- Variable length extension arms for different materials
- Low vacuum alert

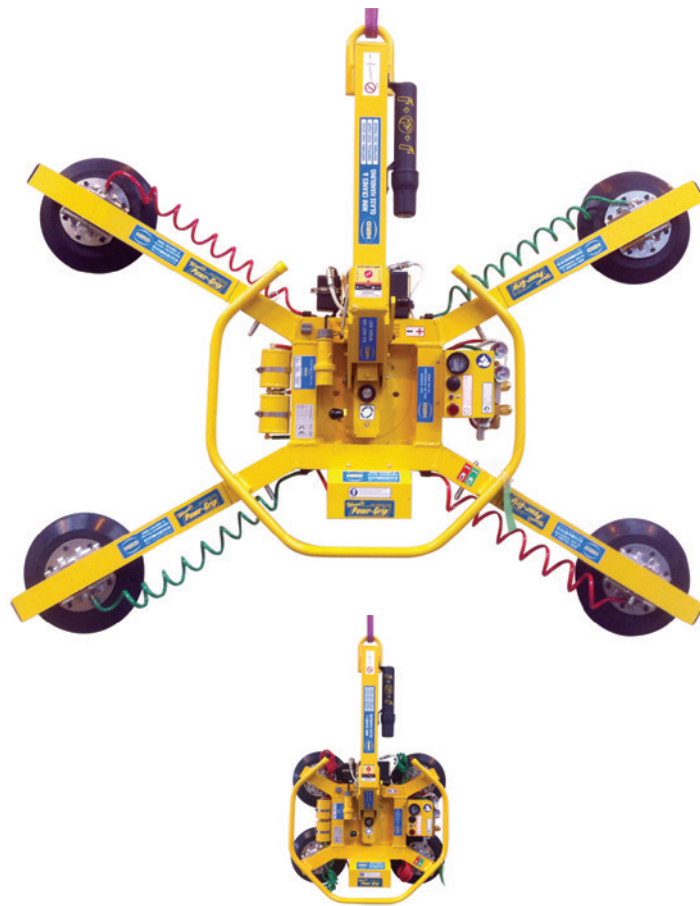

Compact

320kg

 360° rotation

 90° tilt

Technical Specification

Max. lifting capacity	320kg
Weight of lifter	58kg
Number of suction cups	4
Suction cup dimension	305mm Ø
Structural depth	292mm
Power source incl. charger	Battery (110v on-board charger)

Dimensions (mm)

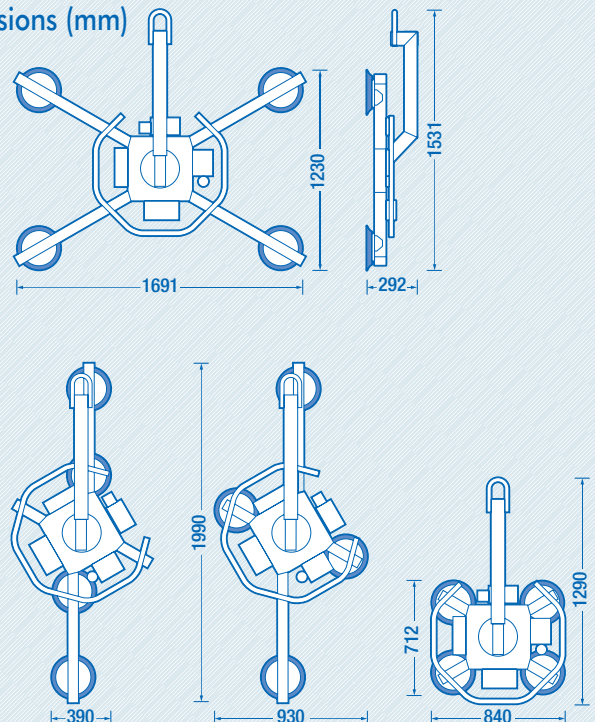

RTITB - accredited vacuum course



Product specifications are subject to change without notice or obligation. The photographs and/or drawings in this document are for illustrative purposes only.