

# MRT2

Dual Circuit Vacuum Lifter

Dual circuit vacuum lifter for safer manual handling and lifting with added rotation.

- 180° degree powered rotation enables operator to manoeuvre loads safely
- Powerful 135kg lifting capacity
- Single person operation
- Can lift a wide range of materials such as glass, plastic and metals
- Safety alarms and interlocks as standard
- Manufactured by Woods Powr-Grip



## 135kg



180° rotation



90° tilt

### Technical Specification

Max. lifting capacity	135kg
Weight of lifter	24kg
Number of suction cups	2
Suction cup dimension	280mm Ø
Structural depth	366mm
Power source incl. charger	Battery (110v on-board charger)

### Dimensions (mm)

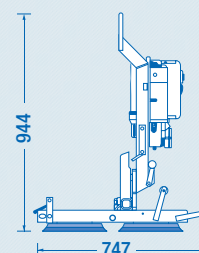
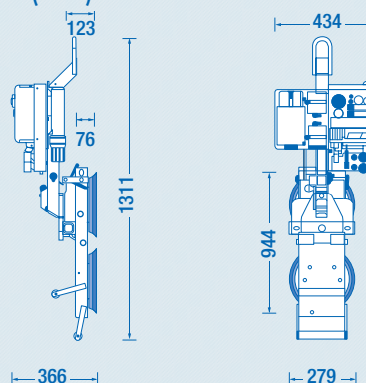

RTITB - accredited vacuum course



Product specifications are subject to change without notice or obligation.  
The photographs and/or drawings in this document are for illustrative purposes only.