



UK and Ireland distributor

# WINLET 785

## Dual Circuit Window & Glass Installation Robot

Simpler lifting for enhanced productivity and safety.

The **Winlet 785** combines pick and carry and lifting duties in one reliable machine. Glazing or glass panels weighing up to 785kg can be lifted, and installed with ease.



Wired remote control



# 785kg

180° rotation

180° tilt

### Technical specification

Max. working height	3,970mm
Max. extension from front bumper to suction cup	2,500mm
Extension capacity at max extension	100kg
Side lift capacity	275kg
Linear	75mm
Fine lift on jib head	200mm
Suction cups (Glass)	4 @ 410mm Ø
Total machine weight	1,422kg
Light weight excluding counterweights	1,142kg
Power source	Battery 110v on-board charger
Remote control	Wired

### Features include



Intelligent load monitoring protects the operator and the load



Multifunction control panel with integrated buttons and signal lights



Easy to adapt to carry other materials including: granite, concrete, plasterboards, steel panels or plates, tiles, wooden panels & doors



Twin wheels for rough terrain (optional)



Vacuum Robots course



Northern  
01482 227333

Central  
01302 341659

Western  
01384 900388

Southern  
0203 174 0658



Compact design makes the Winlet 785 suitable for operating in confined spaces and transported in construction hoists

### Dimensions (mm)

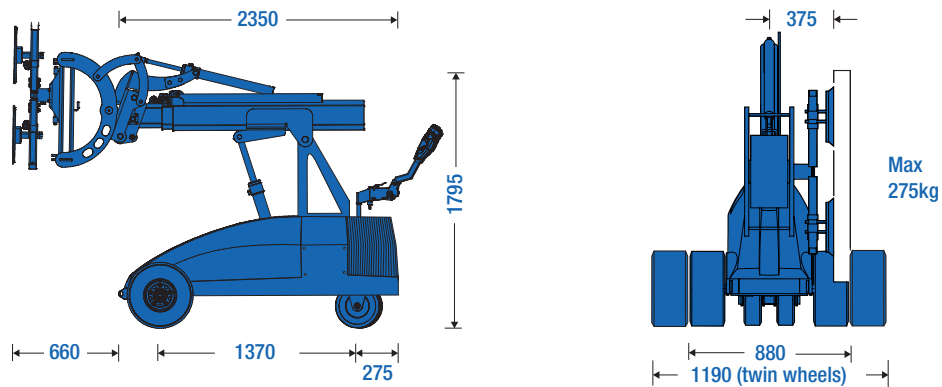

### Pick and place

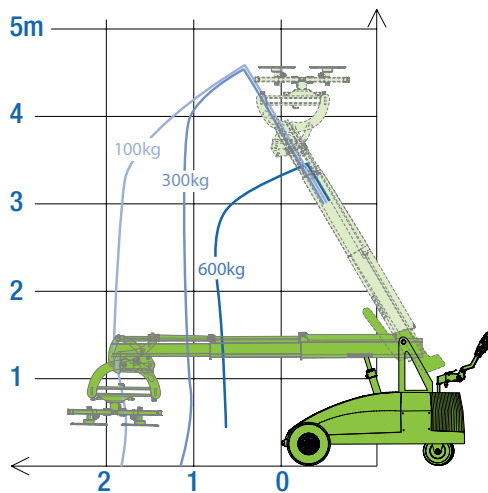

### Reach

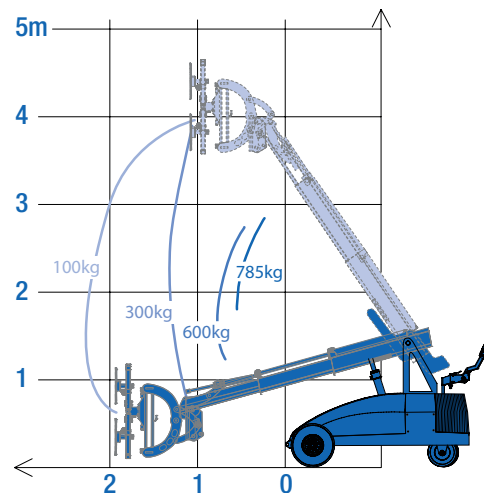

Product specifications are subject to change without notice or obligation. The photographs and/or drawings in this document are for illustrative purposes only.