



# Hydraulica 3500

Dual Circuit Vacuum Lifter

[www.hird.co.uk](http://www.hird.co.uk)

With 3,500kg lifting capacity, this machine enables lifting of large items of glass safer and easier. With the compact design and class leading ability it is affectionately known as 'Brutus'.

- Powered 90° hydraulic tilt
- 360° lockable rotation
- Irregular loads can be lifted with the assistance of individual suction pad shut off
- Very powerful dual independent vacuum circuits
- Powered tilting improves material handling
- Low vacuum alert
- Sliding extension arms



Wired remote control

## 3,500kg



360° rotation



90° tilt

### Technical Specification

Max. lifting capacity	3,500kg
Weight of lifter	750kg
Number of suction cups	12
Suction cup dimension	520mm Ø
Structural depth	385mm
Power source incl. charger	Battery (110v on-board charger)

### Dimensions (mm)

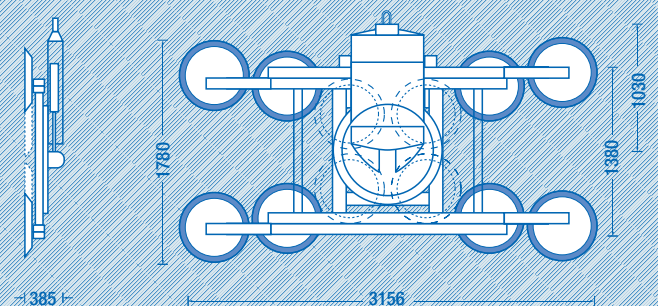
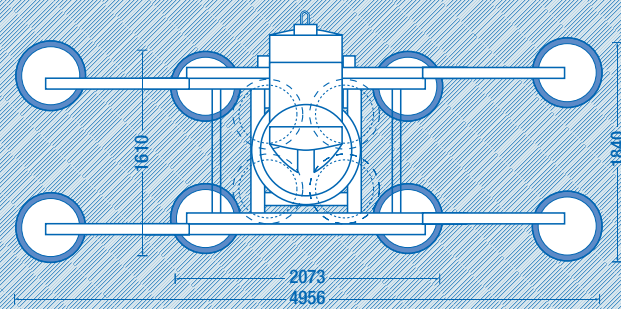

RTITB - accredited vacuum course



Product specifications are subject to change without notice or obligation. The photographs and/or drawings in this document are for illustrative purposes only.

**Northern**  
01482 227333

**Central**  
01302 341659

**Western**  
01384 900388

**Southern**  
0203 174 0658