

Hydraulica 1200

Dual Circuit Vacuum Lifter

The Hydraulica 1200 is a powerful vacuum lifter designed to lift large, heavy and even irregular loads of up to 1,200kg.

- Irregular loads can be lifted with the assistance of individual suction pad shut off
- Very powerful dual independent vacuum circuits
- Powered tilting and rotation improves material handling
- Wheeled stand
- Low vacuum alert
- Cabled remote control



Remote control tilt and rotation



Wired remote control

1,200kg

 270° rotation

 90° tilt

Technical Specification

Max. lifting capacity	1,200kg	750kg
Weight of lifter	360kg (with arms)	
Number of suction cups	14	10
Suction cup dimension	330mm Ø	
Structural depth	300mm	
Power source incl. charger	Battery (110v on-board charger)	

Dimensions (mm)

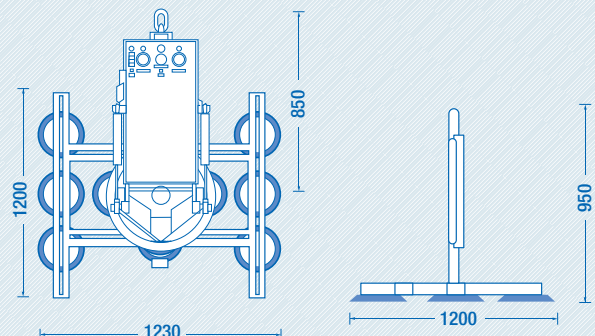
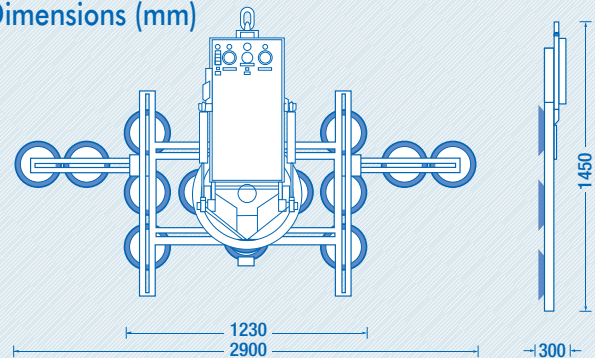

RTITB - accredited vacuum course



Product specifications are subject to change without notice or obligation. The photographs and/or drawings in this document are for illustrative purposes only.