

HIRD

DSZ2 (750kg)

Dual Circuit Slimline Vacuum Lifter

www.hird.co.uk

Hird's DSZ2 is the UK's slimmest vacuum lifter currently available today. Capable of lifting 750kg (with extension arms fitted), it is a strong performer.

- Narrow depth of just 180mm for tight working environments
- Wheeled stand
- Low vacuum alert
- Cabled remote control (2016 model onwards)
- Hydraulically assisted tilt as standard



4 x extension arms with pads



Wheeled stand



Wired remote control

750kg

 360° continuous rotation

 90° tilt

Technical Specification

Max. lifting capacity	750kg	450kg
Weight of lifter	130kg (with arms)	105kg (without)
Number of suction cups	10	6
Suction cup dimension	330mm Ø	
Structural depth	180mm	
Power source incl. charger	Battery (110v on-board charger)	

Dimensions (mm)

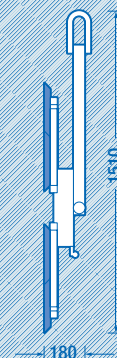
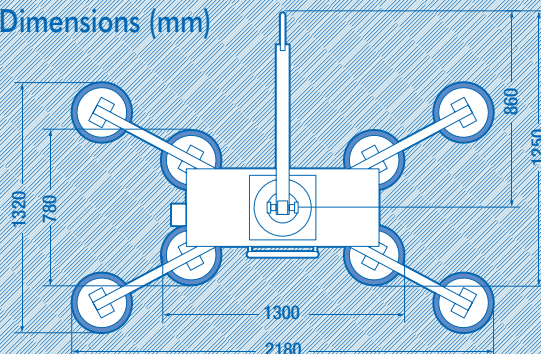

RTITB - accredited vacuum course



Product specifications are subject to change without notice or obligation. The photographs and/or drawings in this document are for illustrative purposes only.

Northern
01482 227333

Central
01302 341659

Western
01384 900388

Southern
0203 174 0658