

HIRD

DSKE2

Dual Circuit Vacuum Lifter

www.hird.co.uk

An excellent lightweight in-line vacuum lifter which has the added option of easily converting to a 6-in-line increasing capacity to an impressive 450kg.

- Short-Eye Hook for glazing under soffits / overhangs
- Ideal for overlights
- Cabled remote control with two button suction release for added safety
- Transport trolley for easy manoeuvrability
- Low vacuum alert
- 110v charging system



DSKE2 without extension arms

Short-Eye Hook as standard

Wired remote control

450kg

 360° continuous rotation

 90° tilt

Technical Specification

Max. lifting capacity	450kg	300kg
Weight of lifter	55kg	45kg
Number of suction cups	6	4
Suction cup dimension	330mm Ø	
Structural depth	170mm	
Power source incl. charger	Battery (110v on-board charger)	

Dimensions (mm)

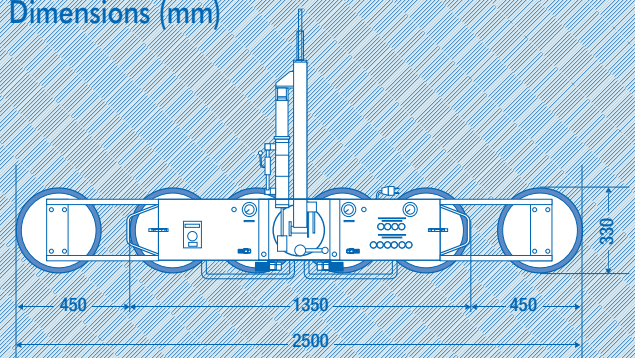

RTITB - accredited vacuum course



Product specifications are subject to change without notice or obligation.
The photographs and/or drawings in this document are for illustrative purposes only.

Northern
01482 227333

Central
01302 341659

Western
01384 900388

Southern
0203 174 0658