

# ERGOMOVER MANIPULATOR

## Material Transport Trolley

A unique self-propelled trolley that provides users with TWO functions for controlling construction materials.

For example, it can set down stacks of plasterboard on trestles and it can raise a stack of plasterboard to the vertical position.



## 1,100kg

### Technical specification

Length (without handle)	1,670mm
Transport loads up-to (in length)	3,000mm
Max. lifting height	725mm
Total machine weight at max extension	425kg
Max travelling speed	0-6km/ph
Wheels	Foam filled puncture proof
Voltage	24 volts
Power source	Battery 110v on-board charger
Lifting function	Electro-hydraulic

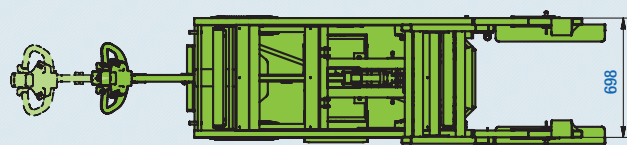
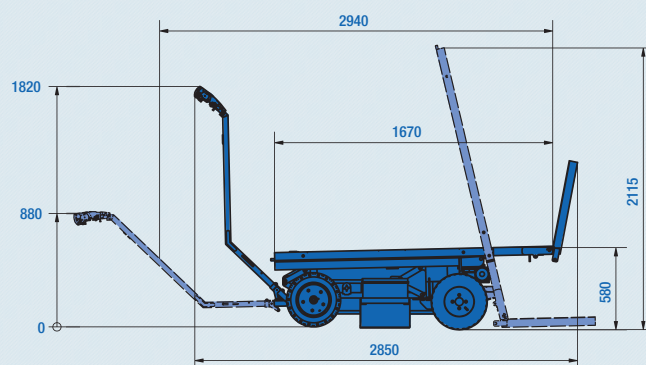

Manual handling awareness training course



Product specifications are subject to change without notice or obligation. The photographs and/or drawings in this document are for illustrative purposes only.