

HIRDEst. 1983
Celebrating 40 Yearswww.hird.co.uk

Hydraulica 750 Compact

Dual Circuit Slimline Vacuum Lifter



Wired remote control

**750kg**

360° continuous rotation



90° tilt

Max. lifting capacity	750kg	600kg
Weight of lifter	180kg	165kg (without arms)
Number of suction cups	10	8
Suction cup dimension	330mm Ø	
Structural depth	340mm	
Power source inc charger	Battery (110v on-board charger)	



RTITB - accredited glass vacuum course



174

Northern
01482 227333**Central**
01302 341659**Southern**
0203 174 0658

Dimensions (mm)

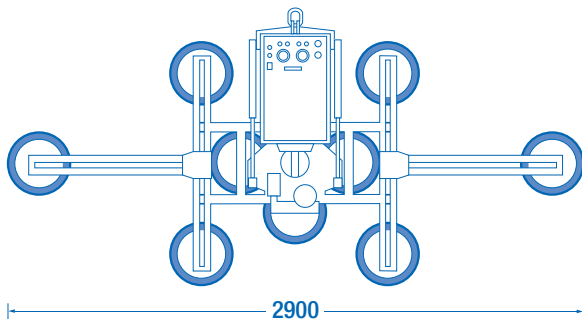
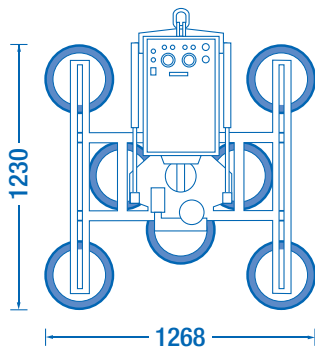

Product specifications are subject to change without notice or obligation.
The photographs and/or drawings in this document are for illustrative purposes only.