

PFHL89 Slimline Vacuum

Vacuum Lifter

An excellent mid-range slimline lifter from Hird. Being lightweight and only 188mm deep it is ideal for fitting material in narrow work areas.

- 180° rotation, 90° tilt
- On-board battery and charger
- Battery energy gauge
- Vacuum gauge
- Vacuum line filter
- Low vacuum warning light



445kg

180° rotation

90° tilt

Technical Specification

Max. lifting capacity	445kg
Weight of lifter	54kg
Number of suction cups	8
Suction cup dimension	230mm Ø
Structural depth	188mm
Power source incl. charger	Battery (110v on-board charger)

Dimensions (mm)

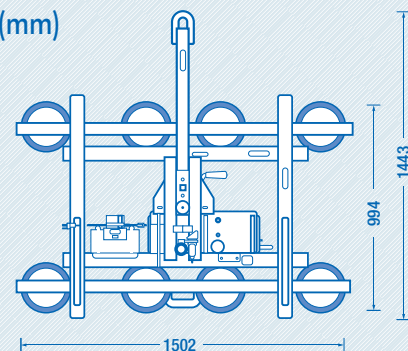

188



RTITB - accredited vacuum course



Product specifications are subject to change without notice or obligation. The photographs and/or drawings in this document are for illustrative purposes only.