

HIRDEst. 1983
Celebrating **40 Years**www.hird.co.uk

MRT4

Dual Circuit Vacuum Lifter



Compact

**320kg**

360° rotation



90° tilt

Max. lifting capacity	320kg
Weight of lifter	54kg
Number of suction cups	4
Suction cup dimension	305mm Ø
Structural depth	291mm
Power source inc charger	Battery (110v on-board charger)
Standard accessories	4 x extension arms



RTITB - accredited glass vacuum course



Dimensions (mm)

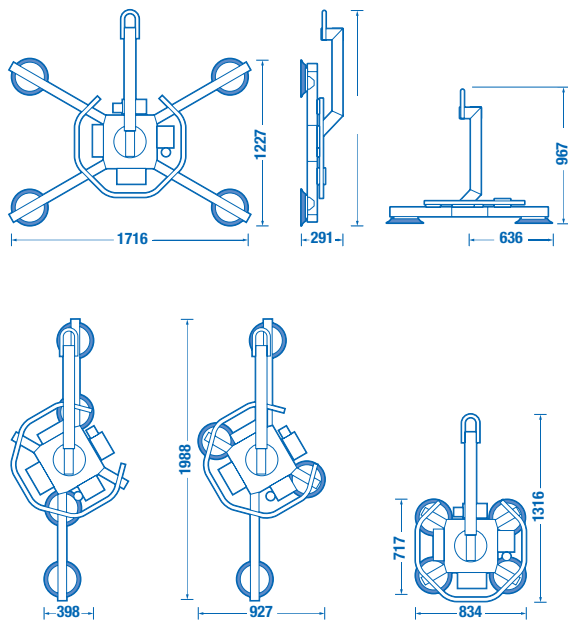

Product specifications are subject to change without notice or obligation.
The photographs and/or drawings in this document are for illustrative purposes only.