

HIRD

Est. 1983
Celebrating 40 Years

www.hird.co.uk

MRT2

Dual Circuit Vacuum Lifter

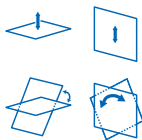

135kg



180° rotation



90° tilt

Max. lifting capacity	135kg
Weight of lifter	37kg
Number of suction cups	2
Suction cup dimension	280mm Ø
Structural depth	364mm
Power source inc charger	Battery (110v on-board charger)



RTITB - accredited glass vacuum course



150

Northern
01482 227333

Central
01302 341659

Southern
0203 174 0658

Dimensions (mm)

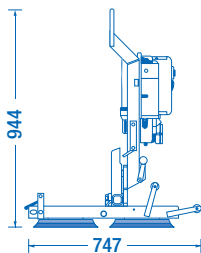
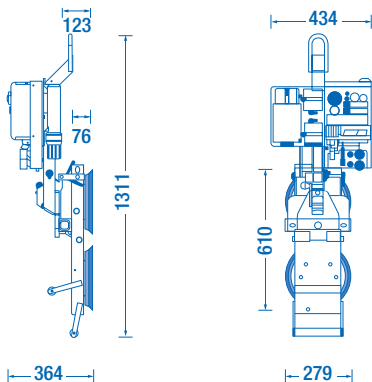

Product specifications are subject to change without notice or obligation.
The photographs and/or drawings in this document are for illustrative purposes only.