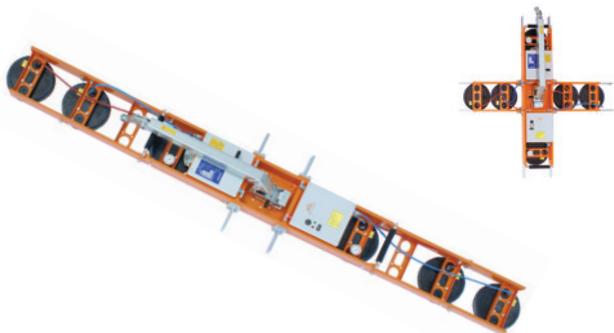

HIRDEst. 1983
Celebrating 40 Yearswww.hird.co.uk

Oktopus GL-LN 600

Dual Circuit Vacuum Lifter

**600kg**

360° rotation



90° tilt

Max. lifting capacity	600kg	450kg	300kg
Weight of lifter	60 - 95kg		
Number of suction cups	8	6	4
Suction cup dimension	330mm Ø		
Structural depth	225mm		
Power source inc charger	Battery (110v on-board charger)		



RTITB - accredited glass vacuum course



Dimensions (mm)

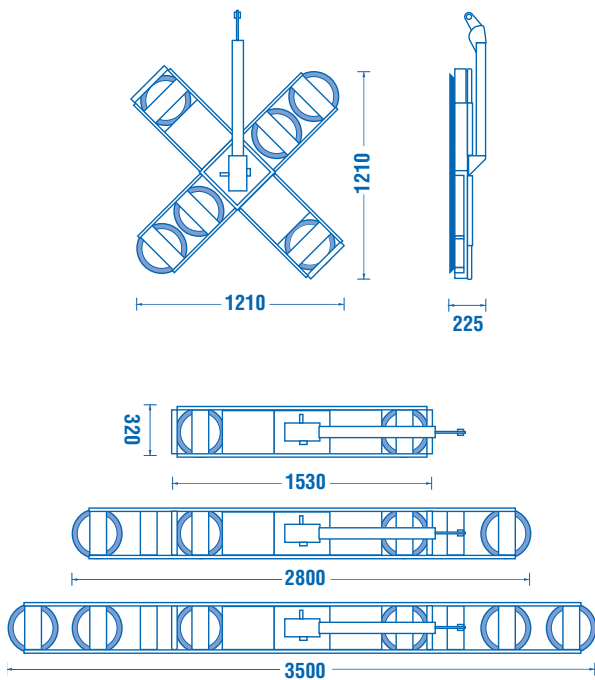

Product specifications are subject to change without notice or obligation.
The photographs and/or drawings in this document are for illustrative purposes only.