



Hydraulica 600 Curved

Dual Circuit Vacuum Lifter

www.hird.co.uk

A heavy duty 600kg curved vacuum lifter using the reliable Hydraulica chassis for heavy curved glass units.

- Powered 90° hydraulic tilt
- 270° Manual and lockable rotation
- Low vacuum alert
- Two or four-on-board maintenance free vacuum pumps

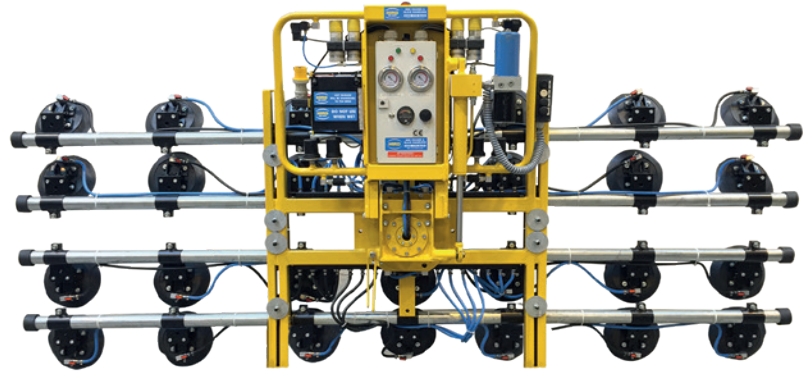

Wired remote control

600kg

270° rotation

90° tilt

Technical Specification

Max. lifting capacity	600kg
Weight of lifter	175kg
Number of suction cups	30
Suction cup dimension	220mm Ø
Structural depth	300mm
Power source inc charger	Battery (110v on-board charger)
Accessories	Radio remote control, wheeled trolley

Dimensions (mm)

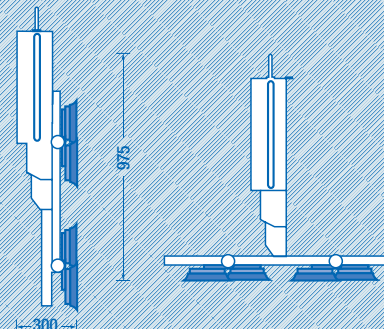
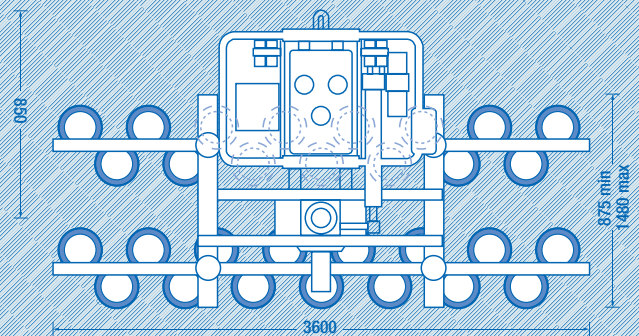

RTITB - accredited vacuum course



Product specifications are subject to change without notice or obligation. The photographs and/or drawings in this document are for illustrative purposes only.

Northern
01482 227333

Central
01302 341659

Western
01384 900388

Southern
0203 174 0658