



Hydraulica 1500

Dual Circuit Vacuum Lifter

www.hird.co.uk

The Hydraulica 1500 combines powerful and safe lifting with flexible operation that supports easy adjustment for the lifting of irregular loads weighting up to 1.5t.

- Irregular loads can be lifted with the assistance of individual suction pad shut off
- Remote control tilt and rotation
- Very powerful dual independent vacuum circuits
- Powered tilting and rotation improves material handling
- Wheeled stand
- Low vacuum alert

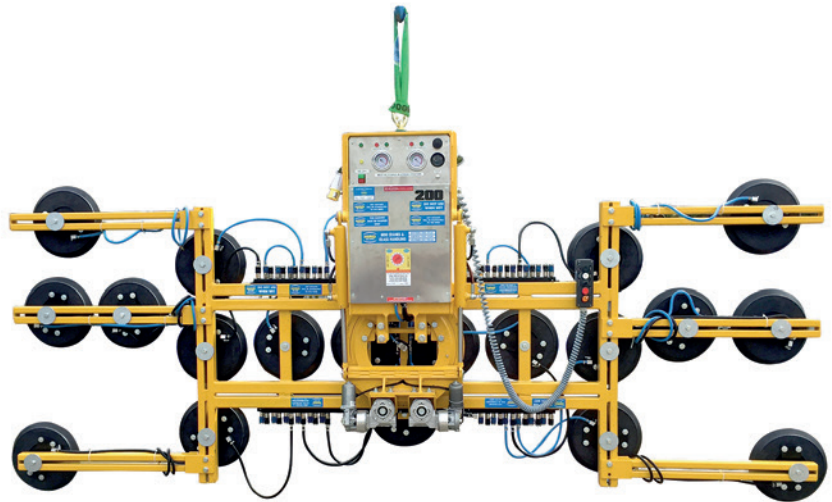

Wired remote control

1,500kg



360° rotation



90° tilt

Technical Specification

| | | | | |
|----------------------------|---------------------------------|---------|-------|-------|
| Max. lifting capacity | 1,500kg | 1,200kg | 900kg | 600kg |
| Weight of lifter | 380kg (with arms) | | | |
| Number of suction cups | 20 | 16 | 12 | 8 |
| Suction cup dimension | 330mm Ø | | | |
| Structural depth | 300mm | | | |
| Power source incl. charger | Battery (110v on-board charger) | | | |

Dimensions (mm)

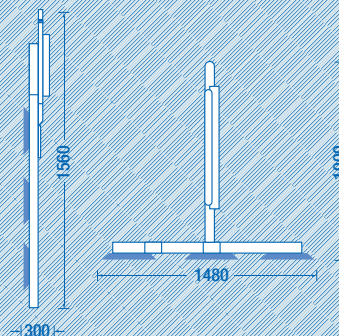
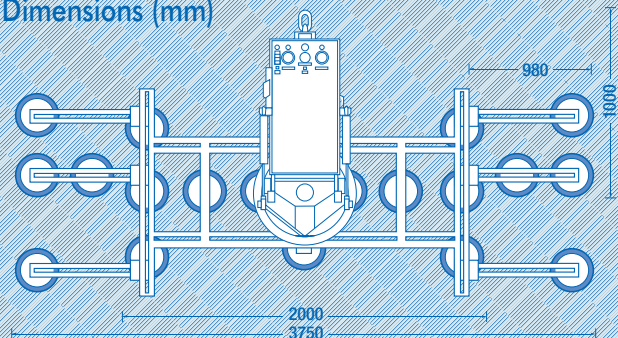

RTITB - accredited vacuum course



Product specifications are subject to change without notice or obligation.
The photographs and/or drawings in this document are for illustrative purposes only.

Northern
01482 227333

Central
01302 341659

Western
01384 900388

Southern
0203 174 0658