



Kappel DSKE2 GRCS

GRC (Glass Reinforced Concrete) & Stone Vacuum Lifter

www.hird.co.uk

Hird's new range of stone vacuum lifters give the user greater control and flexibility. The DSKE-2 GRCS can easily be configured to cater for different load shapes, an excellent all-rounder.

- Specially designed vacuum pads by Kappel for lifting stone & GRC
- Hydraulically assisted tilt for greater control whilst tilting
- Shut-off valves for irregular loads
- Easily converts from a 4 pad to 6 pad machine & from an inline to square configuration

Safety note:

All stone & GRC materials require individual testing prior to lifting operations taking place.

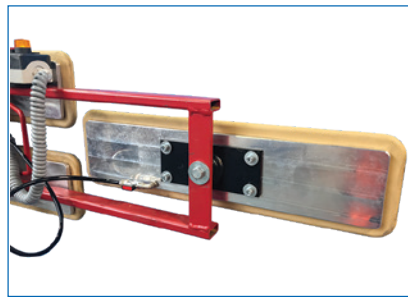

Wired Remote Control

300kg

360° rotation

90° tilt

Technical Specification

Max. lifting capacity	300kg	200kg
Weight of lifter	80kg (with arms)	
Number of suction cups	6	4
Suction cup dimension	600mm x 60mm	
Structural depth	180mm	
Power source inc charger	Battery (110v on-board charger)	

Dimensions (mm)

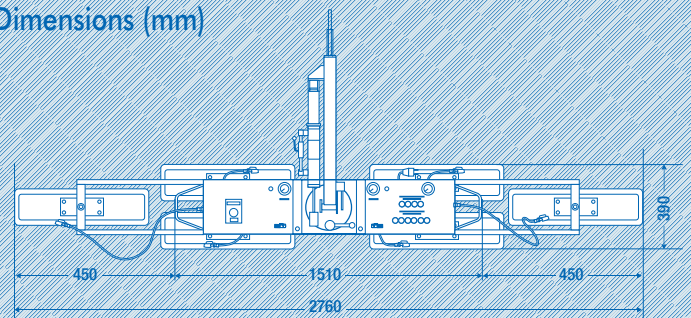

RTITB - accredited vacuum course



Product specifications are subject to change without notice or obligation. The photographs and/or drawings in this document are for illustrative purposes only.

Northern
01482 227333

Central
01302 341659

Western
01384 900388

Southern
0203 174 0658