

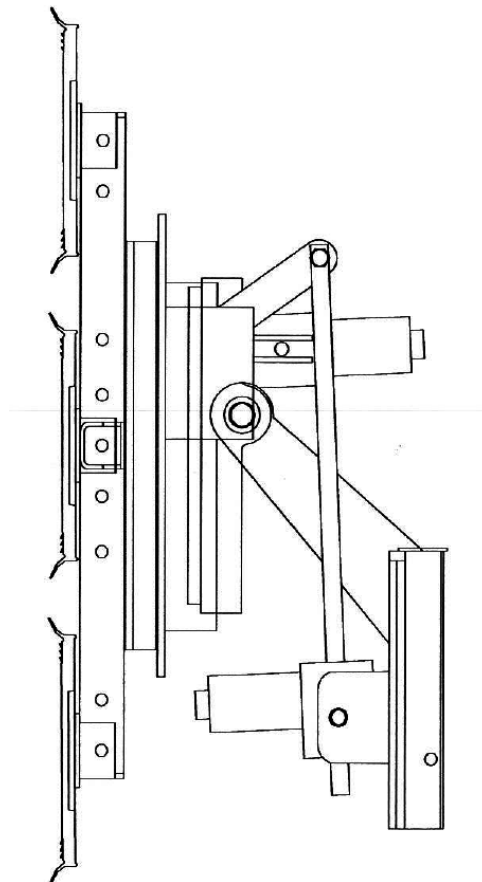

## OPERATOR MANUAL

# KAPPEL GA2-24V



**Northern** (Head Office)  
Tel: +44 (0)1482 227333

**Central**  
Tel: +44 (0)1302 341659

**Western**  
Tel: +44 (0)1384 900388

**Southern**  
Tel: +44 (0)203 174 0658

## Contents

Foreword	1-1
Technical description	1-2
Basic safety information	2-1
Warning instructions and symbols	2-1
Authorised use	2-1
Organisational measures	2-2
Personnel selection and qualifications	2-3
Safety instructions regarding particular operating stages	2-3
Normal operation	2-3
Special work	2-4
Safety instructions for special types of danger	2-4
Electrical energy	2-4
Oils, greases and other chemical substances	2-4
Commissioning	3-1
Charging the battery	3-2
The radio remote control	3-3
The control elements	3-4
Before transporting	3-5
Operation	4-1
Working cycle	4-2
Switching off	4-3

<b>Troubleshooting</b>	<b>5-1</b>
Pump no longer performs correctly	5-1
Lead check	5-2
Leak check for the entire system	5-2
Leak check without suckers	5-2
Electrical malfunction	5-3
Vacuum pump does not switch off when vacuum of -0.72 bar is reached	5-3
No warning signals	5-3
<b>Maintenance</b>	<b>6-1</b>
The suckers	6-1
The vacuum lines	6-1
Leak check	6-2
The spindle motors / The gears	6-3
The vacuum pump	See appendix
<b>Technical data</b>	<b>7-1</b>
Performance data	7-2
Wiring diagram of the GA2-24V	7-3/7-4
<b>Spare parts list</b>	<b>8-1</b>
Test report suction pads 150K	See appendix

Die Fernbedienungen Seite 3-3

1.	Funk Ein/Aus Schalter	Radio on/off switch
2.	Kippen zurück	Tilt back
3.	Schwenken rechts	Swivel right
4.	Drehen Rechts	Rotate right
5.	Ohne Funktion	Without function
6.	Not AUS	Emergency OFF
7.	Kippen vor	Tilt forwards
8.	Schwenken LINKS	Swivel LEFT
9.	Drehen LINKS	Rotate LEFT
10.	Bei Saugen AUS	During suction OFF
11.	Lösen	Release
12.	Funktion	Function
13.	Nach dem einschalten	After switching on
14.	Drücken = Funk EIN	Press = radio control ON
15.	Funk in Betrieb	Radio control in operation
16.	Saugen EIN/Aus	Suction ON/Off

1.	Vakuummeter	Vacuum meter
2.	Saugkreis	Suction circuit
3.	Anschluss	Connection
4.	Funkempfänger	Radio receiver
5.	Stroboskoplampe	Strobe lamp
6.	Blinkt bei Saugen EIN	Flashes when suction is ON
7.	2 x Kontrolllampe Vakuum	2 x control light vacuum
8.	Kontrolllampe Grün an	Control light green on
9.	Kontrolllampe Rot an	Control light red on
10.	Vakuum unter	Vacuum below
11.	Vakuum über	Vacuum above
12.	Hauptschalter	Main switch

## Foreword

These operating instructions are intended to help you become familiar with the GA2 and to use it as intended.

These operating instructions contain important instructions about operating the GA2 safely, effectively, and economically. Observing them helps to avoid repair costs and down time and to increase the reliability and working life of the GA2.

These operating instructions must be supplemented by additional instructions due to existing national accident prevention regulations.

These operating instructions must always be available at the site of use of the GA2

These operating instructions must be read and observed by every person responsible for doing work on the GA2, for example:

- operation, including equipping, troubleshooting during operation, removal of production waste, care
- maintenance (servicing, inspection, repair) and/or
- transport.

In addition to the operating instructions and binding accident prevention regulations applicable for the country of use and the application case, the recognised technical rules for safe and professional work must also be observed.

If you discover errors when reading these operating instructions, or if you have further comments or suggestions, please contact:

Kappel Flachglastechnik GmbH  
Schlachthofstraße 3-5  
87700 Memmingen  
Telephone: +49 (0) 8331/4487  
Fax: +49 (0) 8331/82962

The management appreciates your cooperation.

## Technical Description

The GA2 consists a basic frame and a vacuum cross arm which are attached in such a way that they can be swivelled and rotated electrically 360°. The GA2 can be attached to various crane systems and is controlled by radio remote control. The vacuum cross arm has six suction pads and is intended for flexible use on construction sites. The unipump device is used to generate the vacuum.

The vacuum cross arms can be attached horizontally or vertically. In detail, the device consists of a switch cabinet which holdss he two vacuum reserve tanks and the vacuum pumps. The sucker connections are supplied with a vacuum (suction) or normal compressed air (release) by means of the magnetic valves of the two vacuum circuits. You can switch between SUCTION and RELEASE by using a radio remote control. The two inspection vacuum meters provide information on the exact pressure ratios in the vacuum lines to the individual suckers. The suckers can be blocked individually via the stop valves. In addition, if there is a power stoppage, it is possible with this type of device to set down the cargo safely if both vacuum circuits are perfectly sealed since the vacuum reserve tanks are situated on the vacuum cross arm.

### Mode of operation

Switch the device on at the main switch. The vacuum cross arm must be positioned on the cargo in such a way that all suckers are flat on the smooth clean surface so that the sucker lips can seal completely.

Set the suction switch and wait until the pumps of both vacuum circuits switch off. You can check the vacuum using the vacuum meters1 and 2 on the unipump. If there is a vacuum of  $-0.72$  bar in each vacuum circuit, the load can be lifted. To release the suckers from the cargo, the Suction switch must be operated, then press the release key.

### Caution

The GA2 must **NEVER** be commissioned with only **one** functional vacuum circuit.

## Basic safety information

### Warning instructions and symbols

The following terms and symbols are used in the operator's manual for especially important information:

- |                |   |
|----------------|---|
| <b>Note</b>    | Special information regarding the economical use of the device                                    |
| <b>Caution</b> | Special information regarding requirements and prohibitions for preventing damage.                |
| <b>Danger</b>  | Information or requirements or prohibitions for protecting people or preventing extensive damage. |

### Authorised use

The GA2 has been constructed in accordance with the state of the art and recognised safety regulations. Nevertheless, its use may result in danger to life and limb of the operator or third parties and impairment of the machine or other property may occur.

The machine may only be used when in technically perfect condition, as authorised. The user must be conscious of safety and risks and act in accordance with the instructions. Failures which can interfere with safety must be eliminated immediately.

The GA2 is exclusively for lifting gas-tight, dry materials with firm, flat surfaces. Other use or use going beyond this, for example transporting gas-permeable materials, film-covered materials, wet materials, or rotating or swivelling large or heavy transported goods is not authorised. The manufacturer/supplier is not liable for the damages resulting from this. The risk is carried by the user.

Use as authorised use also includes complying with the operating instructions and the inspection and maintenance conditions.



## Organisational measures

Always keep the operating instructions within reach at the site of use.

In addition to the operating instructions please observe and teach any other generally applicable statutory regulations concerning accident prevention.

Such obligations can also include providing and wearing personal protective equipment.

Please supplement the operating instructions with instructions including supervision and reporting obligations taking into consideration operational corporate circumstances, e.g. relating to work organisation, work processes, personnel used.

The personnel authorised to operate the device must read the operating instructions, particularly the chapter about safety instructions before starting work. It is too late to read the instructions if work has already been started. This applies in particular to personnel who only work on the machine occasionally, e.g. for equipping it and carrying out maintenance work.

Occasional checks should be carried out to ensure that the members of personnel follow the instructions and work in a safety-conscious manner and are aware of risks.

If necessary or if required by regulations, personal protective equipment should be used. Glass should only be transported with the appropriate protective equipment (safety shoes, protective gloves, wrist protectors, helmet etc.) A helmet should be worn at all times when transporting goods above head height.

All safety and danger instructions on the device should be complied with.

All safety and danger instructions on the device should be kept complete and in legible condition.

If there are any safety-related changes to the device or its operation, the device should be stopped immediately and the malfunction should be reported to the relevant office or person.

No changes, attachments or upgrading work that could possibly impair safety should be carried out on the machine without the consent of the supplier. This also applies to the installation and setting of safety equipment and valves as well as to welding on load-bearing parts.

Spare parts must fulfill the technical requirements specified by the manufacturer. This is always guaranteed with original replacement parts.

Vacuum hose lines should be replaced at the specified intervals or at appropriate intervals, even if there are no recognisable safety defects.

Compulsory deadlines or those specified in the instructions for recurring tests / inspections should be complied with

Appropriate workshop equipment is absolutely necessary for performing the maintenance measures.

## Personnel selection and qualification

Work on/with the machine may only be performed by reliable personnel. The legal minimum working age should be observed.

Use only trained or instructed personnel; responsibilities among personnel should be clearly established for operation, equipping, maintenance, and repair.

Ensure that only authorised personnel works on the machine.

Specify a person who is responsible for operating the machine and give him/her the opportunity to refuse to comply with the safety instructions of third parties.

Personnel being trained or instructed, or who are taking part in a general training programme, may only work on the machine when under the constant supervision of an experienced person who is familiar with this situation.

Work on the electrical equipment of the machine may only be performed by an electrician or by trained personnel under the direction and supervision of an electrician in accordance with the rules of electrical engineering.

## Safety instructions on particular operating phases

### **Normal operation**

Avoid all unsafe work practices.

Before starting work, become familiar with the working environment at the site of use. The working environment includes impediments in the work and traffic area, the load bearing capacity of the floor, and cordoning off the worksite from public traffic areas.

Take measures to ensure that the machine is only operated when safe and functional.

Check the machine for externally recognisable damages and flaws at least once per shift. Report any changes that occur (including those to the operating behaviour) immediately to the responsible office/person. If necessary, stop the machine immediately and secure it!

During malfunctions, the machine should be stopped immediately and secured. Malfunctions should be corrected immediately.

The switching on and off procedures should be complied with, and the inspection displays should correspond to the operating instructions.

Always stop work if it becomes dark or if visibility is poor!

## **Special work**

The setting, maintenance, inspection activities and deadlines, including information on replacement of parts and modules stipulated in these operating instructions must be observed. These activities may only be performed by authorised specialists.

Only perform maintenance and repair work when the machine is positioned on flat ground with sufficient bearing capacity and is secured so that it cannot roll away or collapse.

Clean machines, particularly connections and screw connections at the beginning of maintenance/repair work. Do not use aggressive cleaning agents! Use lint-free cloths for cleaning.

Never clean the machine with water or steam jet (high-pressure cleaner).

After cleaning, inspect all vacuum lines for leaks, loosened connections, abrasion and damage. Repair any flaws immediately!

Always tighten screw connections loosened during maintenance and repair work.

## **Safety instructions for special types of danger**

### **Electrical power**

Use only original fuses with the specified current strengths. Switch off the machine immediately during malfunctions to the electrical energy supply.

Work on electrical equipment or operating materials may only be performed by an electrician or by trained personnel under the direction and supervision of an electrician in accordance with the rules and regulations of electrical engineering.

Machine and system parts on which inspection, maintenance, or repair work must be performed, must be switched free of current if required. First check the switched off parts to ensure that they are free of voltage, then ground and short-circuit them, and insulate neighbouring live parts.

The electrical equipment of the machine must be checked regularly. Flaws such as loose connections and melted cables must be repaired immediately.

### **Oils, greases, and other chemical substances**

Observe the safety regulations applicable for the product when using oils, greases, and other chemical substances!

## Commissioning

### Note

- Do not store the GA2 in a damp or very cold (frost) environment. Otherwise there is no guarantee that the installed pumps will function properly.

### Caution

- Always ensure that the suckers are not placed on sharp edges because this could damage the sucker lips. This would lead to leaks in the suction circuit, impairing the functioning of the device.
- Never place the machine with mounted suckers with the rubber surfaces of the suckers on sandy or similar ground. This could damage the sealing lips of the suckers. This would lead to leaks in the suction circuit, impairing the functioning of the device. Or the grains of sand or similar substances could be pressed into the rubber surfaces, leading to damage to the upper surface of the transported goods.

### Danger

- Do not allow heavy rain to fall on the GA2.
- Do not place the GA2 in water.
- Do not convey loads over persons or machines. Cordon off the area under hanging transported goods with wide clearance.

## The unipumpe

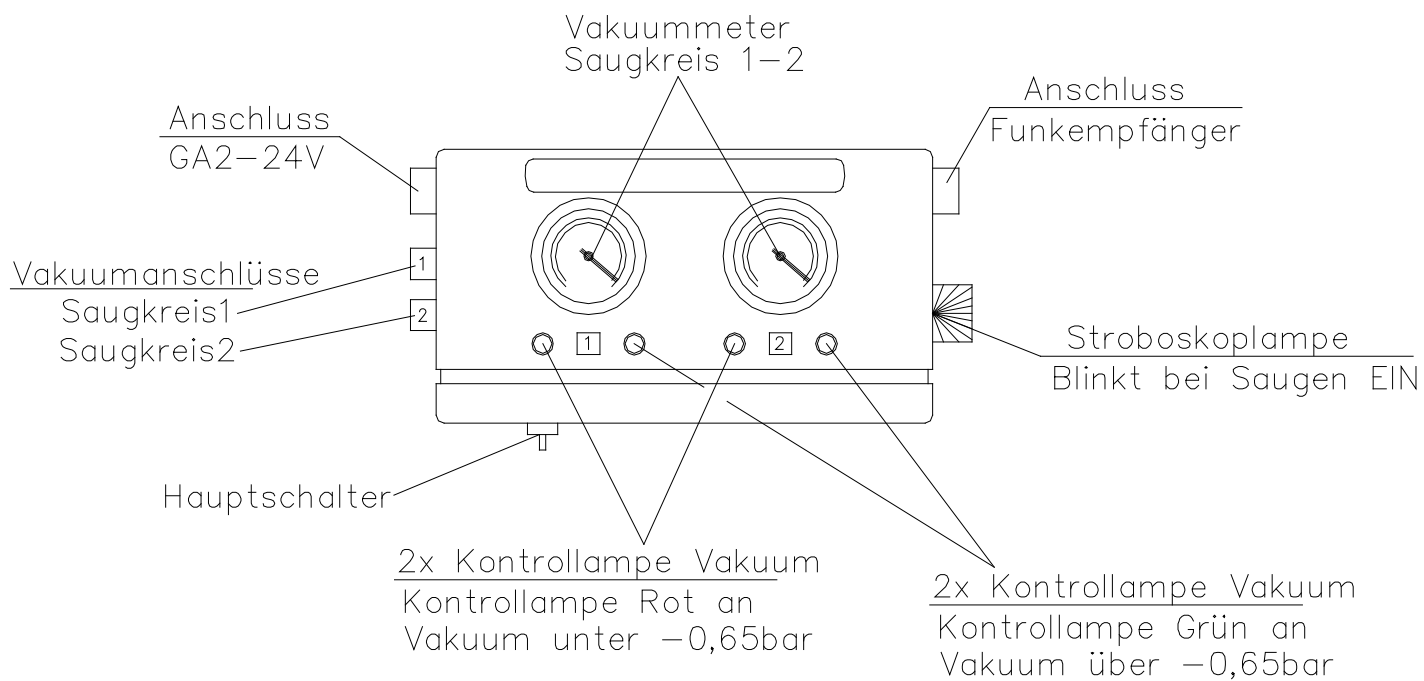

## Caution

The strobe lamp must flash at all times during the lifting procedure  
i.e. SUCTION is ON.

## Attaching the suction pads to the GA2-24V

### Caution

- Blue hose lines = vacuum circuit1
- Black hose lines = vacuum circuit2

### Caution

The suction pads on the vacuum cross arm must always be attached as shown here. To distribute the suction circuits evenly on the cargo.

### With extensions

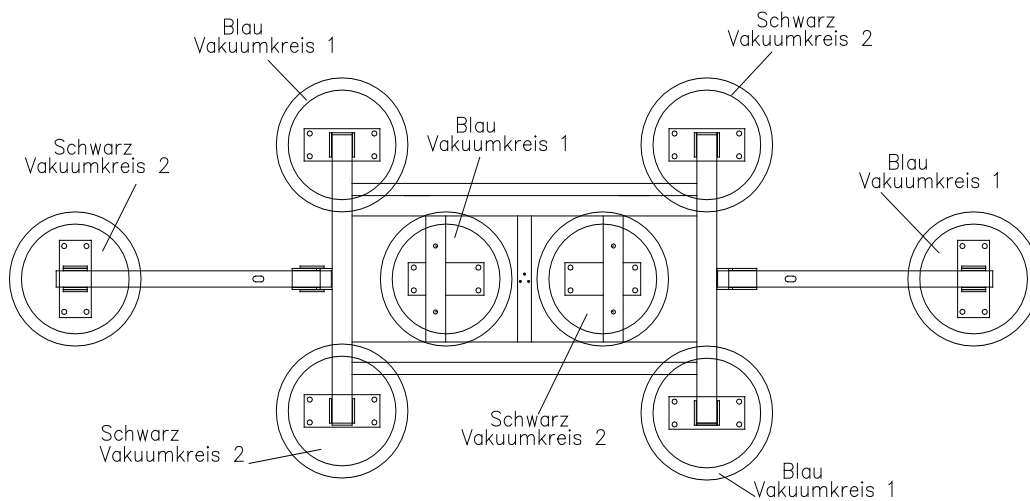

### Without extensions, suction pads attached to the vacuum cross arm

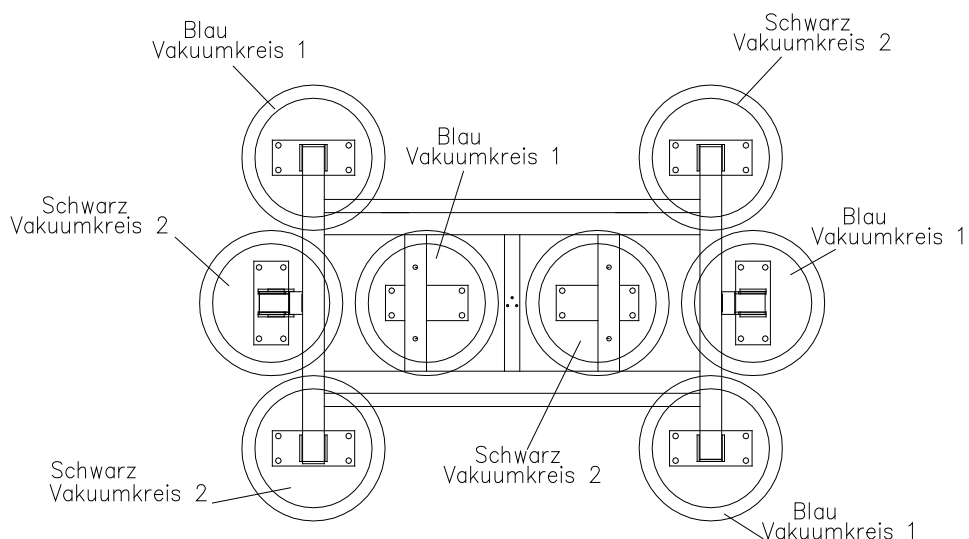

### Caution

Before lifting cargo, make sure that the suction pads are attached via the vacuum couplings and the stop valves on the suction pads are opened.

## Before lifting

Check the GA2 for any externally recognisable damage or flaws.

Switch the device on using the main switch on the unipump and activate the radio remote control.

In order to control the vacuum, the individual suckers (4 / vacuum circuit) are blocked off from the vacuum reserve tanks via the stop valves.

After a short time, a vacuum of -0.65 bar should have formed in each tank. The indicators of the two inspection vacuum meters should then be in the green area.

Then switch the main switch off on the unipump and wait ten minutes. During this time, the indicators on the two inspection vacuum meters should not move. If only one indicator changes, the device is not tight and should not be used until the error is eliminated.

In order to check whether the hoses and the individual suckers are tight, either a larger plate or several smaller plates of a gas-impermeable material must be present. These are held onto the individual suckers and are then gripped. A vacuum of at least -0.65 bar should immediately form in each vacuum circuit. When this happens, the main switch must be switched off. Read the achieved vacuum from the two inspection vacuum meters and compare it with a reading taken about 15 minutes later on both inspection vacuum meters.

If there is no discrepancy, the device is leak-tight and safe to operate. If a discrepancy of more than 5% occurs, the device must be checked until the leak is found. (See Troubleshooting).

Commissioning is complete once the machine switch has been switched back on.

### Caution

- Blue hose line = vacuum circuit1
- Black hose line = vacuum circuit2

### Caution

The GA2-24V must **NEVER** be commissioned with only **one** functional vacuum circuit.

## Operation

### Note

- Do not store the GA2 unit in a damp or very cold (frost) environment. Otherwise there is no guarantee that the installed pumps will function properly.

### Caution

- Always ensure that the suckers are not placed on sharp edges because this could damage the sucker lips. This would lead to leaks in the suction circuit, impairing the functioning of the device.
- Never place the machine with mounted suckers with the rubber surfaces of the suckers on sandy or similar ground. This could damage the sealing lips of the suckers. This would lead to leaks in the suction circuit, impairing the functioning of the device. Or the grains of sand or similar substances could be pressed into the rubber surfaces, leading to damage to the upper surface of the cargo.

### Danger

- Do not allow heavy rain to fall on the GA2
- Do not place the vacuum cross arm in water.
- Do not convey loads over persons or machines. Cordon off the area under hanging transported cargo with wide clearance.



## Working cycle

Before beginning lifting work, the weight of the cargo must be determined. See load capacity Technical data page 7-2.

Arrange the suckers depending on the size of the cargo.

Use the motors via the remote control to determine the position of the carrier into which the cargo is to be gripped.

Position the device on the respective cargo.

### Caution

Before lifting, make sure that the suction pads are attached via the vacuum couplings and the stop valves on the suction pads are opened.

The GA2 must **NEVER** be commissioned with only **one** functional vacuum circuit.

### Caution

- Top-heavy (A) load distribution is not permitted during rotation.
- Ensure bottom-heavy (B) load distribution during rotation.
- The surface must be absolutely free of dust, rust particles, water and similar
- If it is necessary to clean the goods to be transported, use a fat solvent that evaporates without any residue, such as Nitro or brake-cleaner.

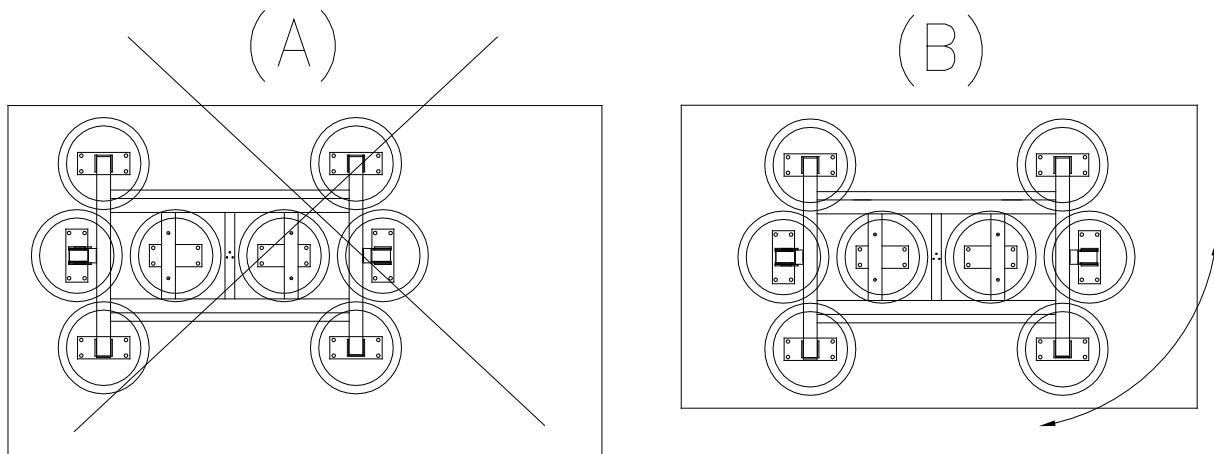

## Caution

- Top-heavy (C) load distribution is not permitted during swivelling.
- (D) load distribution near the ground is not permitted during swivelling.
- Ensure bottom-heavy (E) load distribution during swivelling

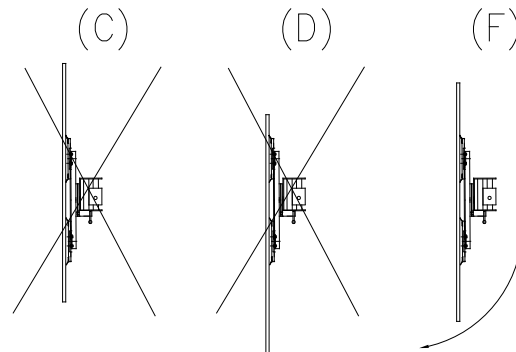

Check that all suckers on the surface are clean and have full contact and, if necessary, press on or align a sucker that is not making contact until it is in the correct position. If this is not done, a vacuum cannot build up and the GA2 can therefore not lift the material. Activate the Suction key.

## Caution

During the lifting procedure, the Suction switch must stay in the ON setting. This means the strobe light on the unilamp must **always** flash during the transport procedure.

## Note

When the Suction switch is on ON, the strobe always flashes, even when the vacuum has been achieved and the green warning lights are on.

Check the vacuum achieved via the two inspection vacuum meters. The signal tone indicates insufficient vacuum. The lifting procedure can take place as soon as there is - 0.72 bar vacuum in both of the vacuum circuits when the pump is switched off, i.e. the signal tone and the red warning light are off, the green lamp is lit.

## Danger

- Do not convey loads over persons or machines.
- If the vacuum sinks below -0.65 bar in both of or in only one of the vacuum circuits during transport work, a signal tone sounds. In this case, try to set down the load as soon as possible so that it does not fall down

The cargo is guided from the side, which means that the operator stands as far as possible from the cargo in order to guide them.

To rotate or swivel the cargo with the remote control, the cargo must always be positioned according to the drawing (B) or (E). It must also be ensured that the rotation or swivelling motion can be performed without danger and that no damage occurs to the cargo.

The cargo is rotated and swivelled from the side, which means that the operator stands outside the area in which the cargo is rotated or swivelled.

If you want to release the cargo, the suction key must be set to OFF and the release key must be activated.

If both inspection vacuum meters indicate 0, the procedure is completed and the cross arm is released from the cargo. It can occur that the device remains stuck to the cargo, but it is released again by the device, which can lead to a small shock that shakes the cargo. Therefore, hold on tightly to the cargo during the release procedure.

## Switching off

After lifting is completed, switch the device off using the main switch.

## Troubleshooting

### Pumps no longer perform correctly

The machine no longer reaches -0.72 bar vacuum.

Please check whether all suckers contact the cargo cleanly; align them if necessary.

Check the suckers and hose lines for possible damage and replace them if necessary.

Check hose clamps for firm fit and tighten them if necessary.

## Leak check

### Leak check for the entire system

You can perform a leak check of the two independently functioning vacuum circuits to find the leak as follows.

First of all, you should check the entire vacuum circuits with all suckers and the hose lines to both vacuum circuits.

To do so, it is necessary to set all suckers on a gas-impermeable, flat material (for example, a metal or glass sheet) that can be gripped. Then switch to Suction On and when the maximum achievable vacuum, as a rule approx. -0.72 bar in each vacuum circuit is achieved, set the main switch on the Unipump off. Read the achieved vacuum from the vacuum meters and record the value in writing. The indicators of the vacuum meters should only change slightly within the next fifteen minutes, not more than 5%. If the result of this test is positive, the vacuum lifting device is tight and you can work with it without risk. If a leak is detected even in only one vacuum circuit, the leak must be corrected immediately or the porous material replaced.

### Leak check without suckers

If the result of the test of the entire vacuum circuit is negative, the next step is to check the vacuum reserve tanks with the supply lines to the connections of the individual suckers (four / vacuum circuit). To do this, the Suction key is pressed and the individual suckers are blocked at the stop valves. Then continue with the leak test as described above. If this test runs positively, it is tight from the vessel areas to the individual stop valves and the error must be in the individual suckers themselves. Connect one sucker after the other and test each one in the same way. To do this, the sucker must be sealed with a gas-impermeable material. The procedure determines the defective area exactly and the error can be corrected quickly by replacement.

### Note

- Blue hoses = vacuum circuit 1
- Black hoses = vacuum circuit 2

### Caution

The suction pads on the vacuum cross arm must always be attached as shown on page 3-4. To distribute the suction circuits evenly on the cargo.

### Caution

The GA2-24V must **NEVER** be commissioned with only **one** functional vacuum circuit.

## Electrical malfunction

Vacuum pumps do not start when the device switch is actuated

- Check safety cutout R7 and R8

Operation not possible

- Have mains connection checked by an expert.
- Vacuum monitor for switching point P2 defective? Replace

Vacuum pumps do not switch off when -0.72 bar vacuum is reached.

- Vacuum monitor P2 defect. Replace.

No warning signals

- Vacuum above -0.65 bar? Device OK.
- Vacuum monitor P1 defective? Replace.
- Signal buzzer defective? Replace.

# Maintenance

## Note

Please note that the trades association requires an annual inspection of vacuum lifting devices by a specialist, in accordance with the accident prevent regulations (VbG 9a-prEN 13155:1998). If you do not have a suitable staff member, we offer a maintenance contract for our vacuum lifting devices which includes annual maintenance including testing and certification. Please contact us for details.

Kappel Flachglastechnik GmbH  
Schlachthofstraße 3-5  
D-87700 Memmingen  
Phone: (+49) 8331 / 4487  
Fax: (+49) 8331 / 82962

## The suckers

The suckers must be cleaned occasionally with a clean cloth. Please do not use a solvent (such as gasoline or similar substances). Never treat the suckers with talc, lubricants, or smoothing agents, as this impairs the adhesion of the suckers, causing the transported goods to slip from them.

## The vacuum lines

The hoses must be inspected occasionally for visible cracks, etc. Replace defective hoses immediately!

### Note

- Blue hoses = vacuum circuit 1
- Black hoses = vacuum circuit 2



## Leak check

A leak test of the two independently functioning vacuum circuits must be performed at least once a week. You should check the entire vacuum circuit with all suckers and the hose lines.

To do this, it is necessary to set all suckers of the vacuum cross bar on a gas-impermeable, flat material (for example, a metal or glass sheet) that can be gripped. Then press the Suction key. The vacuum pumps are switched on and when the maximum achievable vacuum, as a rule approx. -0.72 bar in each vacuum circuit, has been achieved, the pumps are switched off. Now switch off the device with the main switch. Read the vacuum obtained from the vacuum meters and record the value in writing. The indicator of the vacuum meters should only change slightly within the next 15 minutes, not more than 5%. If the result of this test is positive, the vacuum lifting device is tight, and you can work with it without risk.

If the test of only one of the vacuum circuits is negative, you can repair the leak and seal it or replace the leaking material, as described in the Troubleshooting section. The leak must be corrected immediately or the porous material replaced.

## Caution

Always check the operational safety of the pump and the other elements before starting work / commissioning.

## Caution

The GA2-24V must **NEVER** be commissioned with only **one** functional vacuum circuit.

## The spindle motors

- maintenance free

## The gears

- maintenance free

## Technical data

Manufacturer:	Kappel Flachglastechnik GmbH
Designation:	Vacuum lifting device (battery operated)
Type:	GA2-24V
Serial number:	_____
Year of manufacture:	_____
Operating instructions:	Art. no: KA-GA2-24V
Manufacturer's address:	Kappel Flachglastechnik GmbH Schlachthofstraße 3-5 D-87700 Memmingen Phone: 08331/4487 Fax: 08331/82962
After sales service:	Phone: 08331/4487

## Performance data of the GA-24V

### Frame size

Height:	720 mm
Width:	965 mm

### Temperature range

Operating temperature	-1 to +35°C (ambient)
Storage temperature	-5 to +50°C (ambient)

### Dead weight

120 kg

### Vacuum tank

1<sup>st</sup> vacuum circuit 0.5 litre / 2<sup>nd</sup> vacuum circuit 0.5 litre

### Hose connection

6 mm

## Performance data of the GA2-24V

All specifications regarding carrying capacity are based on an evenly distributed load. Furthermore, all suckers must also have sucked on to the transport goods.

### Sucker type 150 K

Diameter:	330 mm
Load capacity on smooth, clean, dry Surface with 60% vacuum	
Vertical:	150 kg
Horizontal:	150 kg
Vacuum connection:	9 mm

GA2 24V delivered with suckers type 150K

Number of suckers: 8

Number of suckers in basic frame: 6

Load capacity vertical: 450kg    Load capacity horizontal: 450kg

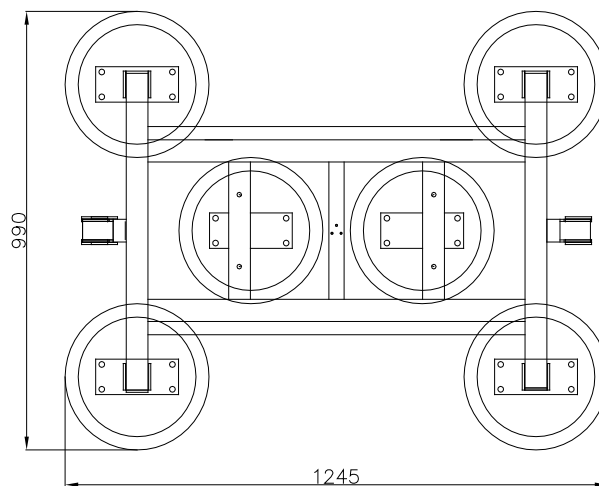

Number of suckers with extensions: 8

Load capacity vertical: 600kg    Load capacity horizontal: 600kg

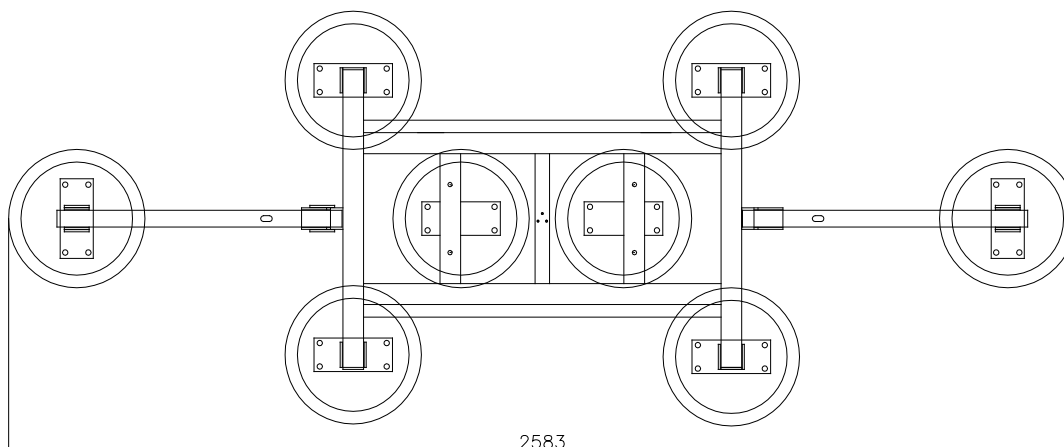

# Wiring diagram of the GA2-24V

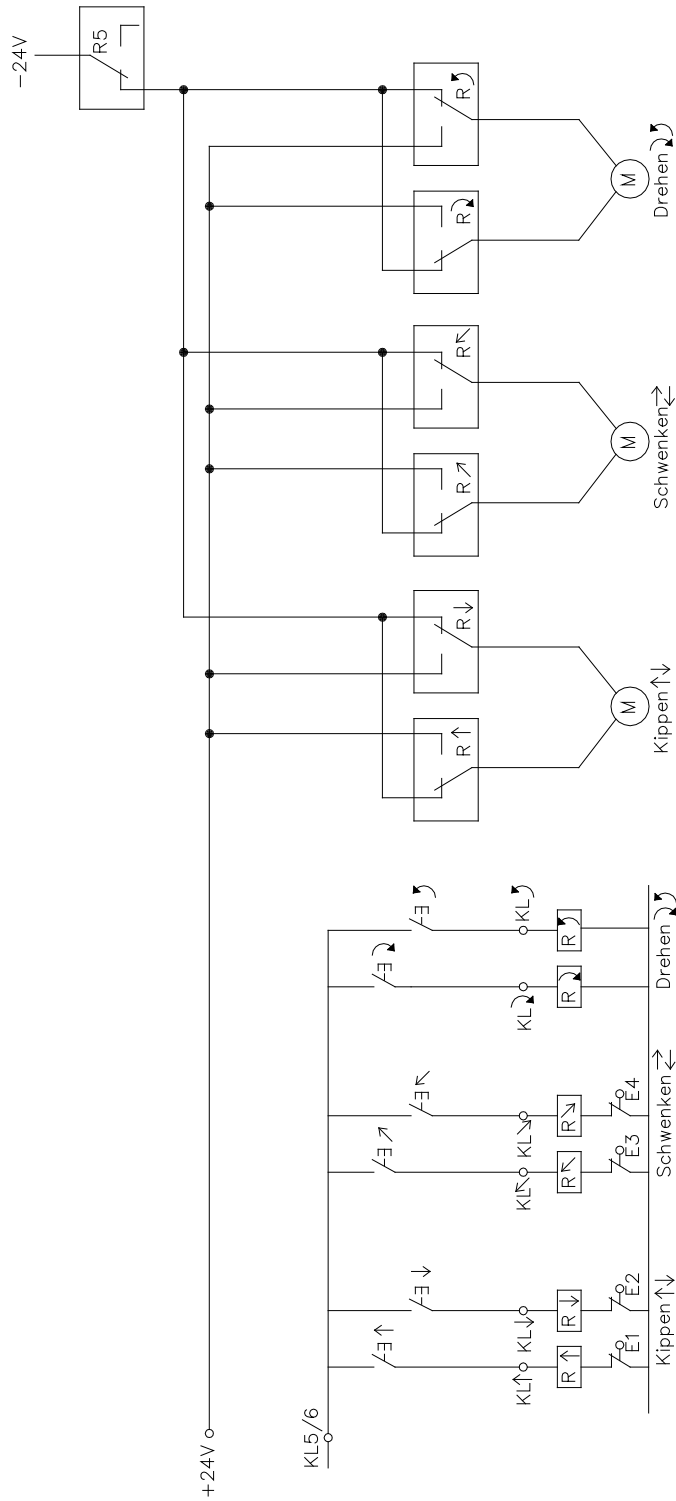



## Spare parts list for GA2-24V

Item	Quantity	Designation
1	4	Vacuum meter 63mm
2	4	3/2-magnetic valve 1/8" 24V DC
3	1	Illuminated selector switch (green)
4	1	Buzzer (horn) 12V DC
5	2	LED-Indicator light 12V ultra green
6	2	LED-Indicator light 12V red
7	1	Strobe light
8	2	Safety cutout 10 Amp.
9	2	Vacuum pump Dynaflo 24V
10	2	Vacuum monitor type 625 (P1)
11	2	Vacuum monitor type 625 (P2)
12	8	Vacuum coupling
13	8	Stop valve
14	1	Radio receiver
15	1	Radio remote control
16	8	Suction pad 150K
17	2	Spindle motor
18	1	Gear
19	1	Motor for Gear



www.hird.co.uk

## HIRD LTD

### Northern (Head Office)

English Street  
Hull HU3 2BS  
**Tel: +44 (0)1482 227333**  
Fax: +44 (0)1482 587710  
Email: info@hird.co.uk

### Central

Shaw Lane Industrial Estate  
Ogden Road, Doncaster DN2 4SQ  
**Tel: +44 (0)1302 341659**  
Fax: +44 (0)1302 341675  
Email: doncaster@hird.co.uk

### Southern

Unit 8, Redhill 23 Business Park  
Holmethorpe Avenue Redhill RH1 2NB  
**Tel: +44 (0)203 174 0658**  
Fax: +44 (0)1737 773188  
Email: london@hird.co.uk

## Vacuum Lifter Pre-Use Inspection Check List

Name of Operator:	Company:
Lifter Manufacturer:	Model No:
Serial No.	Safe Working Load (kg):
Current Examination Date:	Next Examination Date:

No	Item	Yes (✓)	No (X)
1	Check certificate is thorough examination within date		
2	Is a user manual available for the operators use?		
3	Ensure the serial number on the Report of thorough examination, the Peter Hird & Sons test plate and the manufacturers plate all match.		
4	Check for any physical damage to vacuum lifter particularly in weld areas.		
5	Check vacuum pads for rips, tears, quality and cleanliness.		
6	Check vacuum pipes and connections are secure pay particular attention to quick release fittings. Where fitted, ensure all individual pad shut-off valves are open.		
7	Check electrical connections are secure and all switches as undamaged.		
8	Check input mains voltage corresponds with charger voltage - 110v or 240v (circle relevant voltage).	110	240
9	Check battery has sufficient charge and battery charger is functional.		
10	Check Report of Thorough Examination for SWL of current lifter configuration. Is it suitable for load?		
11	Are rotational and tilting movements functional? Check security of handles during function checks.		
12	Energise vacuum lifter on a non porous surface.		
13	Are lights and audible alarms on during vacuum application?		
14	Does vacuum reach sufficient level before oumo switches off?		
15a	Woods lifters only. Does battery gauge illuminate when pump switches off? <b>If No DO NOT USE</b>		
15b	Pannkoke & Kappel lifters only. Does yellow pump light remain illuminated? If No, change 10a fuse (pannkoke) or reset the 25a circuit breaker 52 (Kappel)		
16	Does vacuum drop 5% in ten minute period - If so, do not use, investigate and rectify if possible.		
17	Where fitted, does remote vacuum application and release function correctly?		

Insert particulars of any defect found.

Signature:	Date:
------------	-------

Peter Hird & Sons Limited UK Reg No: 1678 881 VAT Reg No: 347 8749 02



HG1201