

**HIRD**  
**GLASS**

[www.hird.co.uk](http://www.hird.co.uk)

## OPERATOR MANUAL

# KAPPEL HYDRAULICA 1500

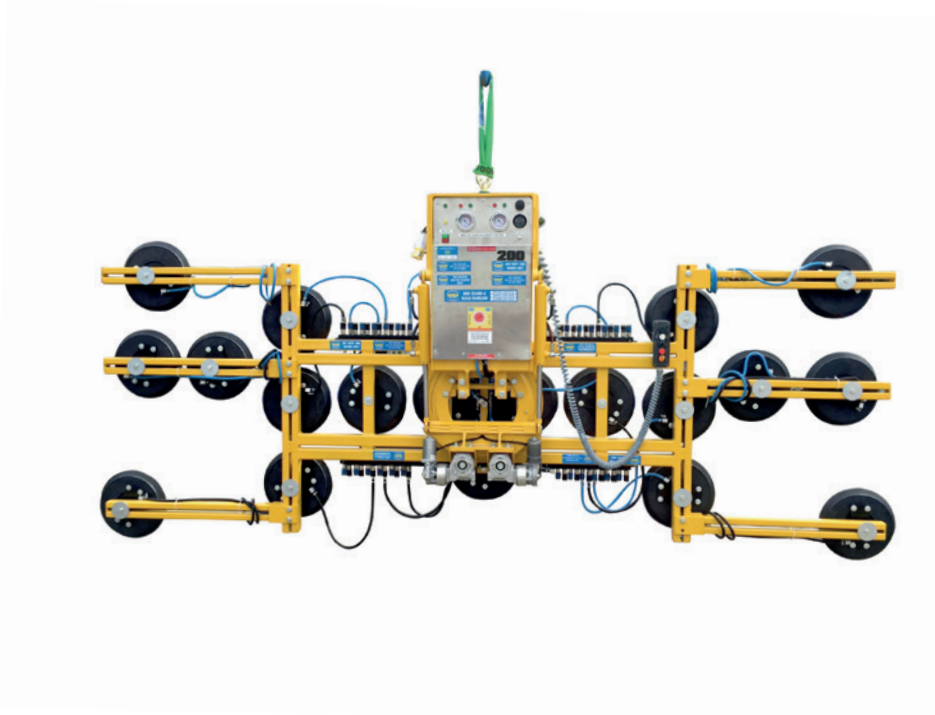

**Northern** (Head Office)  
Tel: +44 (0)1482 227333

**Central**  
Tel: +44 (0)1302 341659

**Western**  
Tel: +44 (0)1384 900388

**Southern**  
Tel: +44 (0)203 174 0658

# Contents

1-1	Foreword.....	3
<b>2-1</b>	<b>General safety information.....</b>	<b>4</b>
2-2	Safety information and danger warnings.....	4
2-3	General safety regulations and organisational measures.....	4
2-4	Personnel selection and qualifications.....	5
2-5	Commissioning, maintenance, repair, cleaning.....	5
2-6	Periodic inspections.....	5
2-7	Electrical power.....	6
2-8	Commissioning and operation.....	6
2-9	Authorised use.....	7-8
<b>3-1</b>	<b>General description of the DSMH2-12V.....</b>	<b>9</b>
3-2	Technical description.....	10
3-3	Front panel top, controls on the device.....	11
3-4	Front panel bottom, load capacity in dual circuit system / suction pads.....	12
3-5	Remote control with cable.....	13
3-6	Radio remote control.....	14
<b>4-1</b>	<b>Commissioning.....</b>	<b>15</b>
4-2	Charging the battery.....	15
4-3	Function check rotating and swivelling.....	15
4-4	Connecting the suction pads to the vacuum circuits.....	16
4-5	Leak check.....	17
<b>5-1</b>	<b>Working cycle.....</b>	<b>18</b>
<b>6-1</b>	<b>Care and maintenance.....</b>	<b>19</b>
6-2	General guidelines for maintenance and servicing work.....	19
6-3	Daily maintenance.....	19
6-4	Weekly maintenance.....	19
6-5	Monthly maintenance.....	19
6-6	Maintenance after 12 months.....	20
6-7	Suction pads.....	20
6-8	Vacuum pumps.....	21
6-9	Geared motor.....	21
6-10	Hydraulic pump with hydraulic cylinder.....	21
6-11	Radio remote control.....	21
6-12	Battery.....	21
6-13	Swivel head.....	21
<b>7-1</b>	<b>Technical data.....</b>	<b>22</b>
7-2	Dimensions of the DSMH2-12V.....	23
7-3	Load capacity, WLL of the DSMH2-12V.....	24
7-4	Maximum size of the sheet material to be transported.....	24
7-5	Wiring diagram of the DSMH2-12V.....	25-26
<b>8-1</b>	<b>Troubleshooting, remedies.....</b>	<b>27</b>

## Content

9-1	<b>Spare parts / Spare parts order</b> .....	28
-----	--	----

### **Appendix**

EK Declaration of conformity

EG Installation declaration

**Option Special suction frame** (see chapter 1-1, note)

Connecting the suction pads to the vacuum circuits on the special suction frame

**Measurements of the DSMH2-12V** with the special suction frame

## 1-1 Vorwort

These operating instructions are intended to help you become familiar with the DSMH and to use it as intended.

These operating instructions contain important instructions about operating the DSM safely, effectively, and economically. Observing them helps to avoid repair costs and down time and to increase the reliability and working life of the Cross arm.

### Note

Upon customer request, it is possible to attach various special suction frames to the vacuum lifters in the DSMH range.

The DSMH with the standard suction frame is depicted and technically described in these operating instructions.

Should your DSMH have a special suction frame, you will find the technical description in the appendix of these operating instructions.

If you discover errors when reading these operating instructions, or if you have further comments or suggestions, please contact:

Kappel Flachglastechnik GmbH  
Schlachthofstraße 3-5  
87700 Memmingen  
Germany  
Tel: +49 (0) 8331/4487  
Fax: +49 (0) 8331/82962  
E-mail : [info@vakuumlifter-kappel.de](mailto:info@vakuumlifter-kappel.de)  
Internet: [www.vakuumlifter-kappel.de](http://www.vakuumlifter-kappel.de)

## 2-1 General safety information

## 2-2 Safety information and danger warnings

The following symbols and designations are used in these instructions to indicate safety and danger information:



### Danger

Indicates a particularly dangerous situation which is to be avoided as it could lead to death or serious injury.



### Warning

Indicates a potentially dangerous situation which is to be avoided as it could lead to moderate or minor injury.



### Caution

Indicates a potentially dangerous situation which is to be avoided as it could lead to death or serious injury.

### Note

Particular specifications for work and operating instructions

## 2-3 General safety regulations and organisational measures

Always keep the operating instructions within reach at the site where the vacuum lifter is used.

The operating instructions are to be complied with.

The operating instruction shall be supplemented by the relevant national regulations for accident prevention.

In addition to the Operating Instructions and the binding accident prevention regulations holding force in the country of use and at the point of use, the recognised regulations for accident prevention and environmental protection are applicable

The personnel authorised to operate and maintain the vacuum lifter must read and understand the operating instructions, particularly the chapter about safety instructions before starting work.

The operator of the vacuum lifter must monitor that personal working with the device must do so in a safe and proper manner in accordance with the instructions.

Protective equipment must be provided for and worn by the operating and maintenance personnel.

Spare parts must be in accordance with the technical requirements stipulated by the manufacturer.



### Danger

Pay attention to the maximum load capacity on the type plate on the device and keep the type plate in a legible condition.



### Danger

Pay attention to the specifications on the lower front panel regarding the maximum load capacity of the suction pads with dual or four-circuit suction equipment and keep them in legible condition. (see Chapter 3-4)



### Danger

No changes, attachments or upgrading work that could possibly impair safety should be carried out on the machine without the consent of the supplier. This also applies to the installation and setting of safety equipment and valves as well as to welding on load-bearing parts.

## 2-4 Personnel selection and qualifications

Operating and maintenance personnel authorised to work with the vacuum lifter must read and understand the operating instructions before beginning work, especially the chapter on General safety instructions.

Work on/with the machine may only be performed by reliable personnel. The legal minimum working age should be observed.

Use only trained or instructed personnel; responsibilities among personnel should be clearly established for operation, equipping, maintenance, and repair.

Ensure that only authorised personnel works on the machine.

Specify a person who is responsible for operating the machine and give him/her the opportunity to refuse to comply with the safety instructions of third parties.

Personnel being trained or instructed, or who are taking part in a general training programme, may only work on the machine when under the constant supervision of an experienced person who is familiar with this situation.

## 2-5 Commissioning, maintenance, repair, cleaning

Secure a wide area around the repair area

Do not use machine parts as climbing aids.

Compulsory deadlines or those specified in the instructions for recurring tests / inspections should be complied with. These activities must be carried out by specialist personnel only.

Only carry out maintenance work if the machine is parked on level and sufficiently supporting ground and is secured against rolling away.

Clean the machine, in particular the connections and screw joints, before carrying out maintenance / repair work. Do not use any aggressive detergents for cleaning,

Never clean the device with water or steam cleaning device (high pressure cleaner).

After cleaning, check all vacuum lines in case there are leakages, loose connections, chafe marks and damage

Always tighten any screwed connections that have been loosened during maintenance and repair!

When handling oil, grease and other chemical substances, observe the product-related safety regulations

## 2-6 Periodic inspections



### Danger

Please note that the trade association determines that an annual inspection of vacuum lifting devices is carried out by an expert (VbG 9a-prEN 13155:1998). All periodic inspections are to be conducted by the operator.

### Note

We carry out an annual inspection stipulated by the trade association either on our premises or on your premises. During the annual inspection which we carry out, the load capacity of each individual sucker is checked.

## 2-7 Electrical power



### Danger

Work on electrical equipment or operating materials may only be performed by an electrician or by trained personnel under the direction and supervision of an electrician in accordance with the rules and regulations of electrical engineering.

Machine and system parts on which inspection, maintenance, or repair work must be performed, must be switched free of current if required. First check the switched off parts to ensure that they are free of voltage, then ground and short-circuit them, and insulate neighbouring live parts.

Use only original fuses with the specified current strengths. Switch off the machine immediately during malfunctions to the electrical power supply.

The electrical equipment of the machine must be checked regularly. Flaws such as loose connections and melted cables must be repaired immediately.

## 2-8 Commissioning and operation



### Danger

Secure vacuum lifters only to suitable and technically correct lifting equipment with sufficient load capacity



### Danger

The DSMH may only be commissioned when all the vacuum circuits are functional.

Before starting work, become familiar with the working environment at the site of use. The working environment includes impediments in the work and traffic area, the load bearing capacity of the floor, and cordoning off the worksite from public traffic areas.

Danger areas must be clearly indicated by warning signs and cordoned off by barriers. Please ensure that instructions regarding danger areas are observed.

Before the initial commissioning as well as the daily starting up, ensure that a sight check and the stipulated inspection work is carried out.

The vacuum lifter should be operated only when all the existing safety devices, control lamps, the acoustic warning signal, the flashing light and the vacuum meters are functional.

Any damage to the vacuum lifter and any changes in the operating behaviour must be reported immediately to the responsible person:

- The vacuum pump no longer reaches the minimum deepest final pressure of approximately - 0.72 bar.
- Rotation or swivelling is not possible.  
(see Chapter 8-1 Troubleshooting)

Refrain from any unsafe working methods.

Unsafe working methods:

- failing to observe the General Safety Instructions
- Failing to carry out inspection and maintenance work sufficiently
- Improper use (see Chapter 2-9)

Ensure that after the vacuum lifters have been switched off / shut down, they are protected from unauthorised use.

Always stop work if it becomes dark or if visibility is poor.

## 2-9 Authorised use

The vacuum lifters in the DSMH series have been constructed in accordance with the state of the art and recognised safety regulations. Nevertheless, their use may result in danger to life and limb of the operator or third parties and impairment of the machine or other property may occur.

Vacuum lifters may only be used when in technically perfect condition, as authorised. The user must be conscious of safety and risks and act in accordance with the instructions. In particular, failures which can interfere with safety must be eliminated immediately.

- Safety devices are not ready for operation.
- Changes in operational behaviour, (see Chapter 2.8)

Vacuum lifters in the DSMH series are exclusively for transporting gas-tight, dry materials with firm, flat surfaces.

Use as authorised use also includes complying with the operating instructions and the inspection and maintenance conditions.

The following is inappropriate use of vacuum lifters of the type DSMH.

- Exceeding the permissible load capacity (WLL)
- Dropping the cargo before setting down the load
- Pulling loads at angles
- Tearing, pulling or dragging loads
- Conveying persons
- Conveying loads above persons
- Standing under suspended loads
- Not keeping loads under constant observation
- Use in potentially explosive environments
- Use in ambient temperatures of below +1° or above +40° C
- Use in rain



### Danger

Gripping and lifting gas-permeable materials, film-covered materials, wet materials is not allowed.



### Danger

Gripping and transporting cargos with unclean and uneven surfaces is not allowed.



### Danger

The surface of the suckers and the cargo must be absolutely free of dust, rust particles, water and similar.

If it is necessary to clean the goods to be transported, use a fat solvent that evaporates **without any residue**, such as Nitro or brake-cleaner.

The surface must **not** be cleaned with glass-cleaner, detergent or similar.

The suction pads must not be placed under protective hoods when the cargo is being gripped.



### Danger

The operator must keep the vacuum meters in view and monitor them at all times.



### Danger

If the following happen during lifting work:

- The red flashing lamp starts to flash.
  - The acoustic warning signal sounds and the red warning lamp lights up
- Set the cargo down and move away from it.





**Danger**

Uneven load distribution of the cargo is not permitted during rotation.

Fig. 0-1

Ensure that the load is distributed evenly during rotation.

Fig. 0-2

Fig. 0-1

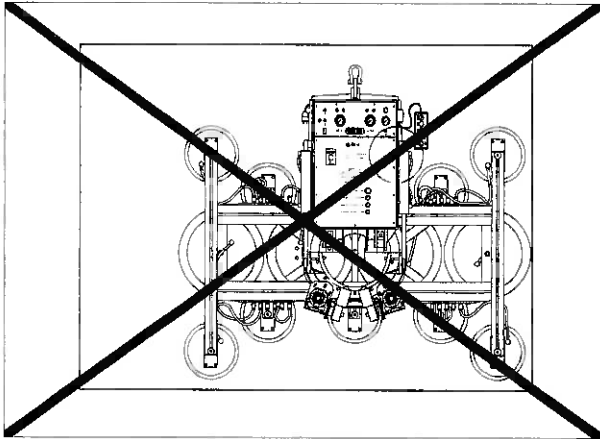
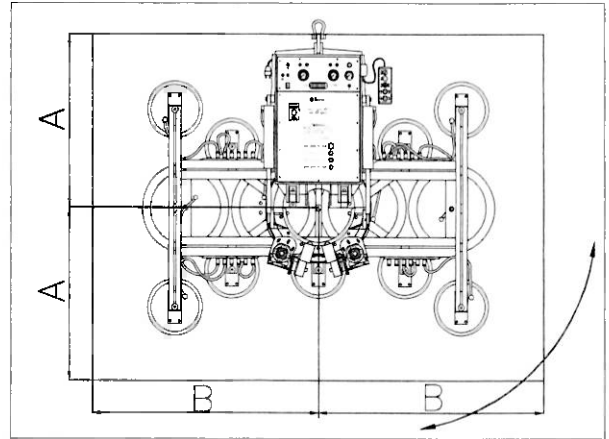

Fig. 0-2



**Danger**

Top-heavy or load distribution near the ground is not permitted during swivelling.

Fig. 0-3

Ensure that the load is distributed evenly during swivelling.

Fig. 0-4

Fig. 0-3

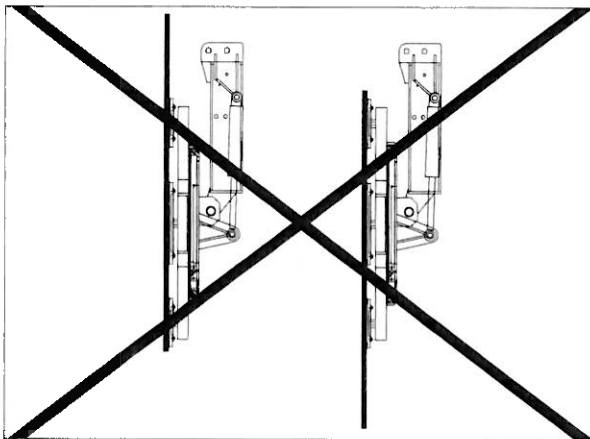
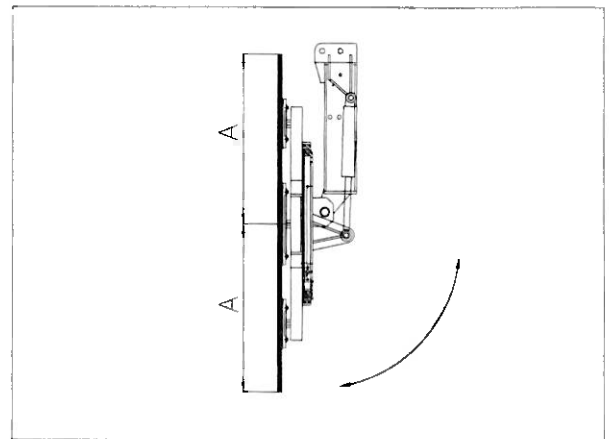

Fig. 0-4



**Danger**

Rotating or swivelling cargo that has too large a surface is not permitted.

(See Technical Data, Chapter 7-4)

### 3-1 General description DSMH2-12V

Fig 05

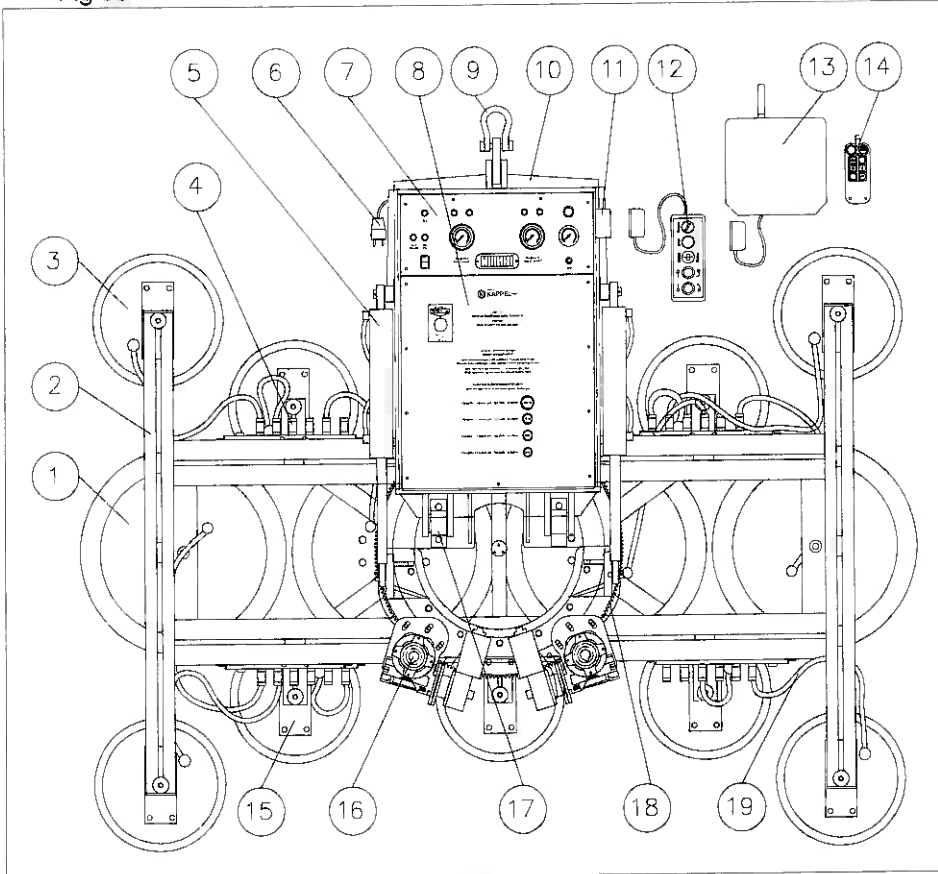

1. Suction pad type 400k
2. Suction frame
3. Suction pad type 150K
4. Vacuum coupling, blue = vacuum circuit 1 / black = vacuum circuit 2
5. 2 pcs. hydraulic cylinder (swivel)
6. Mains plug
7. Front panel top
8. Front panel bottom
9. Shackle
10. Top frame
11. Plug connection 10-pole, for remote controls
12. Remote control with cable
13. Radio receiver
14. Radio remote control
15. Suction pad mount
16. 2 pcs. geared motor (rotation)
17. 2 pcs. pivot bearing
18. Swivel head
19. Vacuum line, blue = vacuum circuit 1 / black = vacuum circuit 2

## 3-2 Technical description

- The vacuum lifters in the DSMH series are vacuum lifting devices for various load capacities.
- They can be fitted with various special suction frames so that they can be adapted to many different types of cargo and to lift and transport the cargo in stable way
- In these operating instructions, the DSMH is depicted with the standard suction frame and a technical description is given. If you DSMH has a special suction frame, you will find the technical data for it in the appendix of these operating instructions.
- The suction frame can be rotated electrically 360 degrees and also swivelled 90 degrees hydraulically by two geared motors.
- They are intended for flexible use on construction sites and on various crane systems and anywhere where no 220 to 240 volt connection is available.
- It is suspended from the upper frame by a shackle.
- The upper frame houses the vacuum reserve tanks, the vacuum pumps, the battery charging device, the battery and the hydraulic pump.
- In addition to easy installation on a crane or similar device, the DSMH range offers the safety advantage that in general no vacuum supply hose or voltage supply line is required as is the case with separated devices (cross arm, vacuum pump).
- In addition, it is also possible to lower transported goods during a power outage with this type of device as long as all vacuum circuits are perfectly sealed, because the vacuum reserve tanks are located in the vacuum lifter.

### Vacuum generation

- The devices are equipped with two vacuum circuits working independently from each other (dual circuit suction system).
- This means that each vacuum circuit should be able to maintain its load capacity with double safety.
- Two vacuum pumps (one vacuum pump per circuit) are used to generate vacuum.
- Each vacuum circuit has a vacuum reserve tank, two vacuum switches, a one-way valve, two magnetic valves and a control vacuum meter.
- The suckers are supplied with a vacuum (suction) or normal compressed air (release) by means of the magnetic valves (suction/release) of the circuits.
- The inspection vacuum meters provide information on the exact pressure ratios in the vacuum lines to the individual suckers.
- Insufficient vacuum is signalled by the red warning lamps and the acoustic warning signal.
- The suckers can be blocked individually via the stop valves.

### Power supply

- Power is supplied by the built-in battery.
- A voltage display indicates the battery charge level.
- The charging circuit voltage for the built-in charger is 220-240 volt AC (50/60 Hz).
- In order to avoid draining the batteries unnecessarily, the vacuum pumps are switched off by the vacuum switch when the vacuum reaches -0.72 bar in the vacuum reserve tank, and switches back on only when the pressure falls below approx. -0.68 vacuum.
- This avoids premature draining of the batteries due to the pumps being allowed to run unnecessarily

### Operation

- The on / off switch is situated on the device
- The rotation and/or swivelling movement and the changeover between SUCTION and RELEASE is carried out by a remote control with a cable or with radio control.



#### Danger

Note the maximum load capacity of the vacuum lifter on the type plate.



#### Danger

Vacuum lifters in the DSMH series are exclusively for transporting gas-tight, dry materials with firm, flat surfaces.

### 3-3 Front panel top, controls on the device

Fig. 06

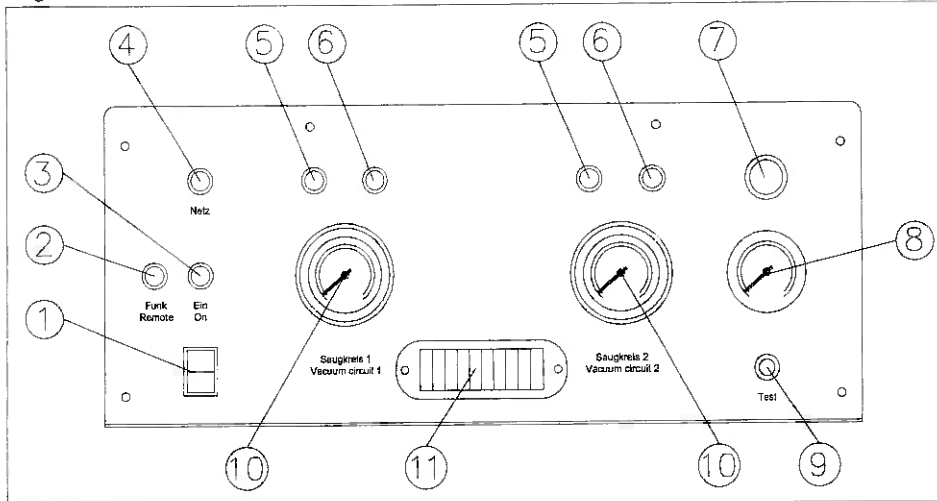

No.	Description	Function	Reaction
1	on / off press switch	with the switch On device ready for use	
2	control lamp yellow, permanent light	is lit when radio receiver is active	
3	control lamp yellow, permanent light	is lit when On device ready for use	
4	control lamp green, permanent light	is lit in mains operation	
5	2 pcs. warning lamps red, permanent light	when the permitted vacuum level is lower than -0.60 bar this lights up	set down cargo and move away
6	2 pcs. control lamp green, permanent light	is lit when there is -0.65 bar vacuum in the vacuum circuit	
7	buzzer signal tone	when the permitted vacuum level is lower than -0.60 bar the acoustic warning signal sounds	set down cargo and move away
8	voltage display	when the test key is pressed the charge level of the battery is displayed	
9	test key	when the test key is pressed the charge level of the battery is displayed	
10	vacuum meter	shows the current vacuum level in the vacuum circuit	
11	flashing light red red, flashing	flashes when suction is off	set down cargo and move away



#### Danger

Goods may only be transported when the vacuum meters in both vacuum circuits have reached the minimum final vacuum of -0.72 bar (green area).

This means that the vacuum pumps in both vacuum circuits must have switched off.



#### Danger

If during lifting:

- the red flashing light starts to flash  
due to unintentional unplugging, cable breakage or other external factors;
- the acoustic warning signal sounds and the red warning lamps light up;  
set down cargo immediately und move away.

### 3-4 Front panel bottom, load capacity in duel circuit system / suction pads

The load capacity for all Kappel's suction pad types is indicated on the bottom front panel on the vacuum lifter (Fig. 07)

This makes it easy for the operator to calculate the permitted load capacity on the basis of the built-in suction pads before each lifting procedure.

#### Example for calculating the permitted load capacity

There are 4 pcs. type 400k and 10 pcs. type 150k attached to the suction frame

4 pcs: type 400k load capacity 200kg/pcs. = 800kg load capacity

10 pcs. type 150k load capacity 75kg/pcs. = 750kg load capacity

The permitted load capacity = 800kg + 750kg = **1550kg**

Fig. 07

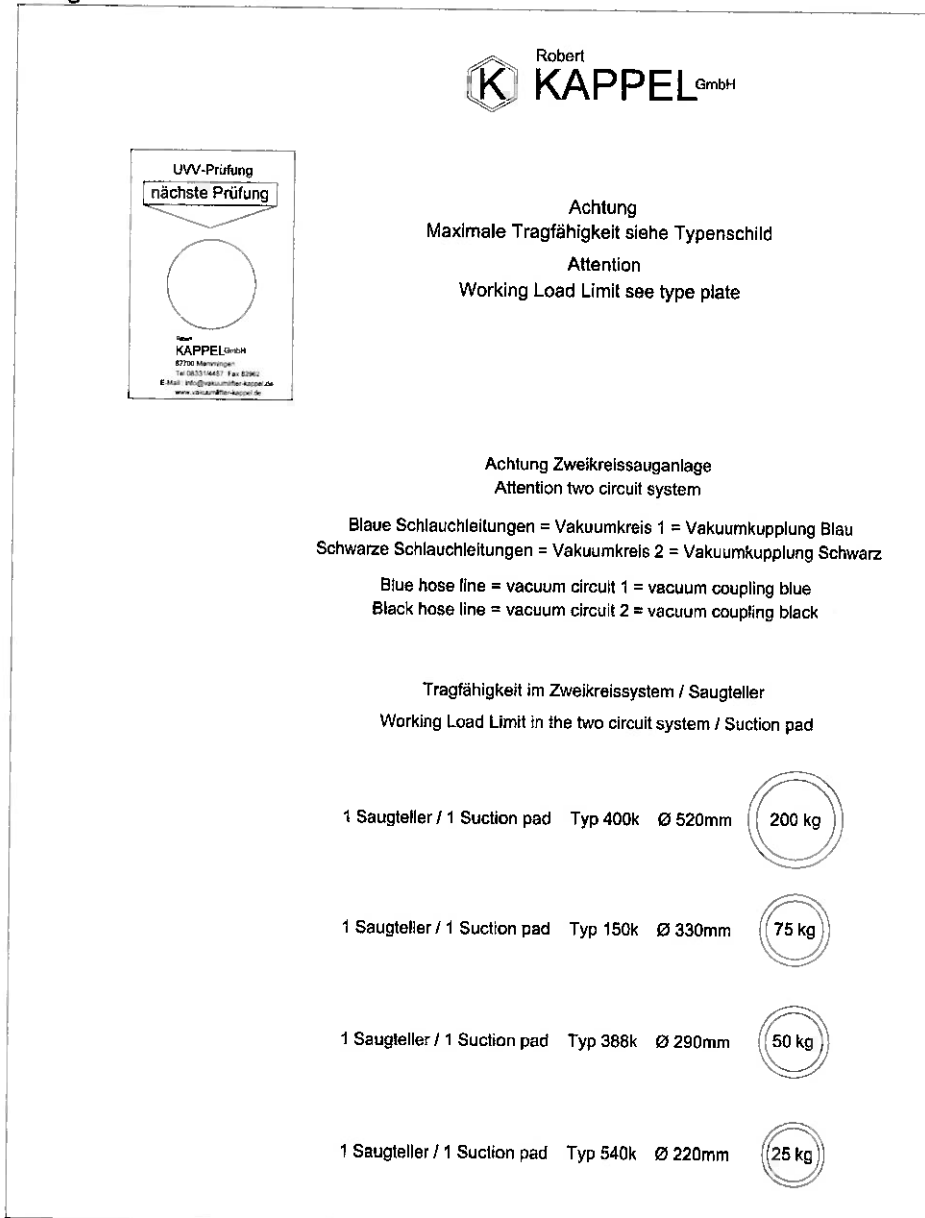

#### **Danger**

The load capacity indicated on the type plate on the device refers to the maximum load capacity of the vacuum lifter.

The operator is obliged not to exceed the load of the suction pads attached and the maximum load capacity of the vacuum lifter.

### 3-5 Remote control with cable

Fig. 08

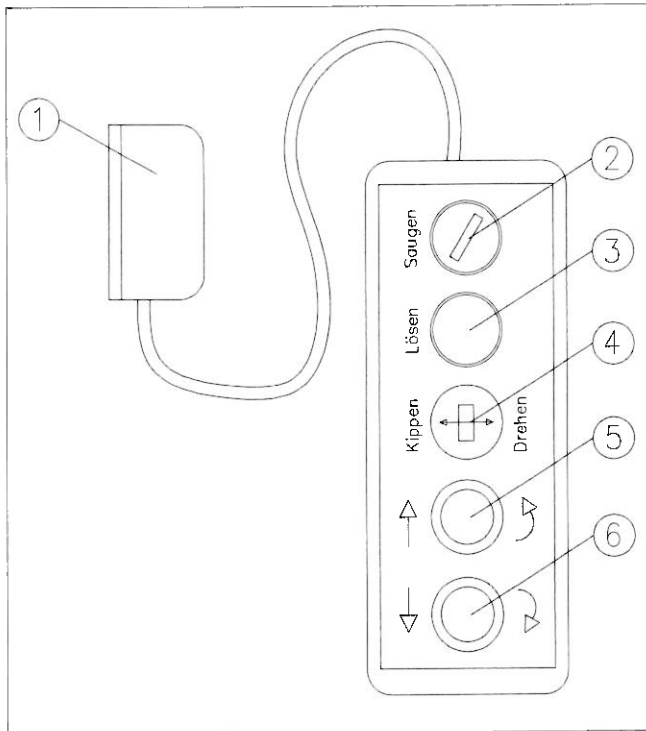

No.	Description	Function
1	plug connection 10-pole	the remote control is connected to the vacuum lifter via the plug connection
2	suction On / Off selector switch orange, permanent lights	is lit when suction is On switch setting 1 switches the valve to suction On switch setting 2 switches the valve to suction Off
3	release key red	by keeping the Release key pressed when on switch setting 2 suction Off, the valve switches to Release (discharge)
4	rotation or swivel selector switch / toggle switch	switch over between rotation or swivel
5	rotation or swivel key white	when toggle switch is on rotation = turn to the left when toggle switch is on tilt = swivel vertically
6	rotation or swivel key black	when toggle switch is on rotation = turn to the right when toggle switch is on tilt = swivel horizontally



#### Danger

During lifting, the suction function must **NOT** be switched off



#### Danger

During lifting, if the plug connection (1) on the remote control is separated.  
 - due to unintentional unplugging  
 - cable breakage or other external factors;  
 the acoustic warning signal sounds and the red flashing light starts to flash;  
 set down cargo immediately und move away.

### 3-6 Radio remote control

Fig. 09

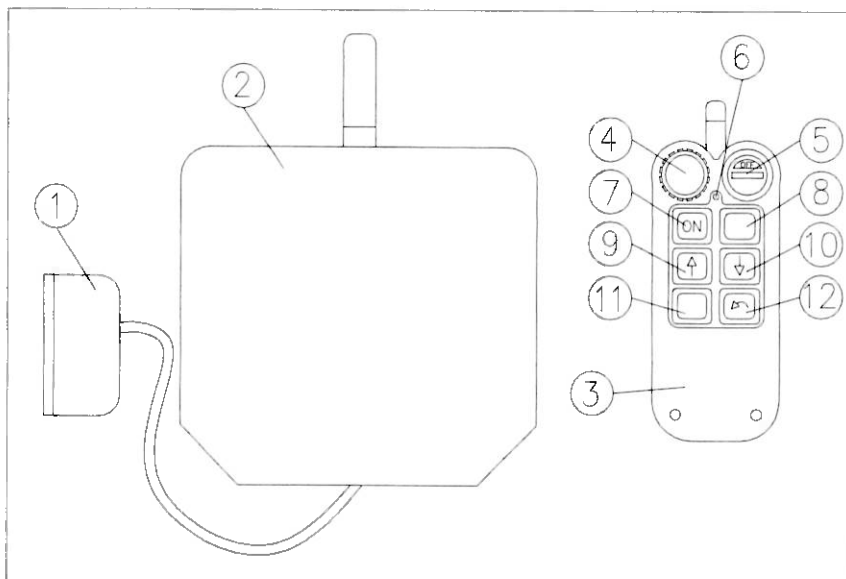

#### Note

The radio remote control can be used up to approx. 100 m in the open.



#### Caution

The batteries in the radio transmitter have to be charged each time work is commenced

No.	Description	Function
1	plug connection 10-polig	The radio receiver is connected to the vacuum lifter via the plug connection
2	radio receiver	radio reception for radio remote control
3	radio remote control	operation of the vacuum lifter
4	emergency Off key red	by pressing the Emergency Off key, the rotation and swivel functions are switched off, the suction function remains active
5	radio control On-Off rotary switch	switch on radio control = rotate to the right =to Start, then back to ON switch off radio control = rotate to the left to OFF
	Note	when the radio receiver is active, the yellow control lamp is lit radio control on the front panel top
6	control lamp radio control On, Not Off	radio control On = flashes green Radio control Off = lamp off emergency off pressed = flashes red
7	suction On-Off key On	press key = switches valve to Suction On when suction is On, press key = switches valve to Suction Off
8	without function key white	
9	rotation or swivel key arrow upwards	when function is on rotation = rotate to the left when function is on swivel = swivel to vertical position
10	rotation or swivel key arrow downwards	when function is on rotation = rotate to the right when function is on swivel = swivel to horizontal position
11	release key red	when kept pressed when suction is Off, the valve switches to release (discharge)
12	rotation or swivel latching key spin button to the left	press key = switch function for key 9 and 10 to rotation when function is on rotation, press key = switch over function for 9 and 10 to swivel



#### Danger

During lifting, if the plug connection (1) on the remote control is separated.

- due to unintentional unplugging
- cable breakage or other external factors;

the acoustic warning signal sounds and the red flashing light starts to flash;  
set down cargo immediately und move away.

#### Danger

If the radio connection is interrupted during lifting, e.g. if the distance is too big, empty batteries in the radio remote control, the suction function stays on ON.



Consequently, it is possible to set down the cargo. The cargo must, however, be set down immediately and the reason for the interruption in the radio connection must be eliminated.

## 4-1 Commissioning



### Danger

Operating personnel must read carefully and understand the operating instructions and carry out all inspection work before the initial commissioning of the vacuum lifter.



### Caution

When using the radio remote control. (See Chapter 3-6, Radio remote control).

During commissioning and operation, the General Safety Information (see Chapter 2) should be observed.

Before commissioning, the vacuum lifter should be stored at room temperature not below 0°C.

The delivery should be checked to ensure that it is complete, the packaging should be disposed of in an environment-friendly way.

## 4-2 Charging the battery

Before connecting the vacuum lifter, check that the operating voltage indicated on the type plate corresponds to the power supply available. If they do not correspond, the device must not be used.

Connect the vacuum lifter at the mains plug to the supply network using an extension cable. (see Chapter 3-2, Fig. 05)

The charging procedure can be checked in the voltage display after pressing the test button. (see Chapter 3-3, Fig. 06)

After the charging procedure has finished, a deflection of 12 Volt should be visible on the voltage display after the test key has been pressed.

The battery is charged after a maximum of 12 hours.

Remove the extension cable from the supply network.

This completes the charging procedure

### Note

After the transporting work is completed, switch the device off with the switch in order not to drain the battery unnecessarily.

If the battery is not charged, the devices in the DSMH range can also be used in mains operation. You just need to ensure that there is an appropriate cable leading to the power supply.



### Warning

Please avoid clamping, grinding and squashing the mains supply line.

## 4-3 Function check rotating and swivelling

Use a shackle to hang the vacuum lifter onto a crane hook or similar.

Switch the device to On with the On / Off switch.

Carry out the rotation-swivel functions using the remote control with cable and with the radio remote control (see Chapter 3-5 and 3-6). If a function is not possible, the device must be inspected (see Troubleshooting/Remedies)

### Note

Rotation and/or swivelling movements can only be carried out when all the vacuum pumps have switched off. Swivelling can only be carried out when the DSMH is hanging from a crane hook, i.e. the hydraulic pump is in the vertical position.



#### 4-4 Connecting the suction pads to the vacuum circuits

In order to ensure even load distribution in the event of a power failure in one of the vacuum circuits, the suction pads must always be distributed on the vacuum circuits as shown in (Fig. 10 - 10.2). The position of the suction pads in the suction frame determines which vacuum circuit is to be connected. This means that the vacuum circuit on the suction pad to be connected must always be retained, even when fewer suction pads are attached.

Connect the vacuum lines on the suction pads to the vacuum couplings on the suction frame.

**B** = blue hoses                      vacuum circuit 1                      vacuum couplings blue  
**S** = black hoses                      vacuum circuit 2                      vacuum couplings black

suction frame, Fig. 10

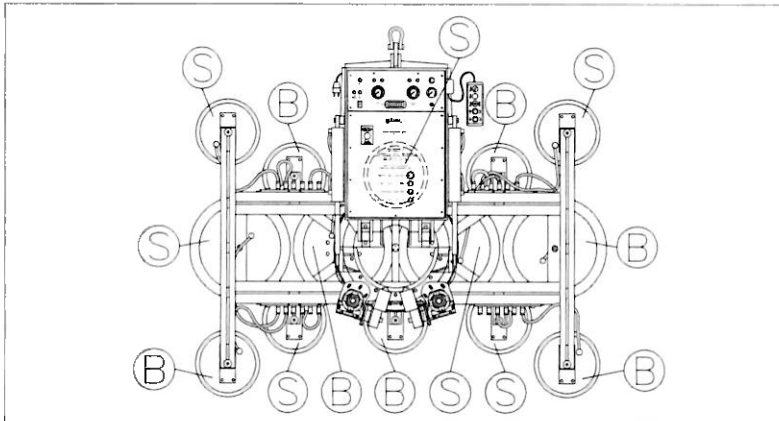

suction frame with four extensions, Fig. 10.1

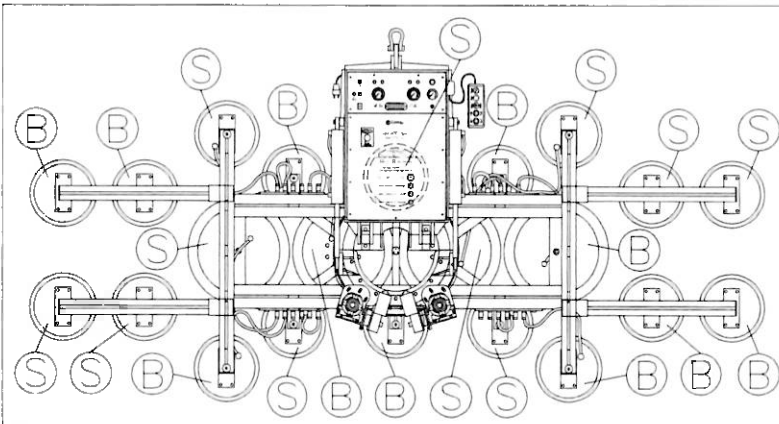

suction frame with two extensions, Fig. 10.2

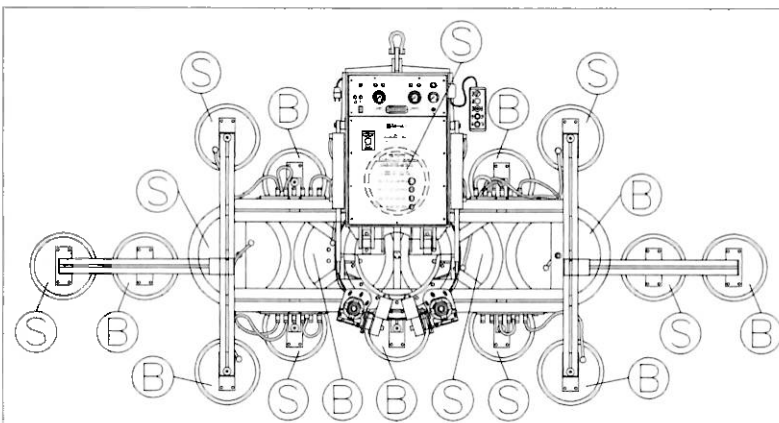

#### Danger

The DSMH must only be commissioned with **two** functional vacuum circuits

Before every transport operation, ensure that all suction pads are connected to the vacuum lines on the vacuum couplings.

## 4-5 Leak check

A leak check must be carried out before commissioning the vacuum lifter and at weekly intervals.

Place the vacuum lifter with **all** suction pads onto a plate of gas-impermeable, flat material.

Check that all the suction pads are clean on the surface and that the whole surface is in contact and, if necessary, press any suction pads that are not in full contact or adjust until it is in the right position.

Switch the vacuum lifter to On using the On/Off switch. (The red flashing light begins to flash)

Once this has happened, the selector switch Suction is set to ON. (The red flashing light extinguishes)

During this process, the acoustic warning signal and the two red warning lamps are lit up as long as the required vacuum has not yet been reached.

Once the acoustic warning signal and the red warning lamps have extinguished, the two control lamps are lit green; a short period later, the indicators of both vacuum meters must have reached a value of approx. -0.72 bar (green range). The vacuum pumps then switch off.

After the vacuum pumps in all the vacuum circuits have switched off, switch off the vacuum lifter using the On/Off switch.

Read the achieved vacuum from the vacuum meters and record the value in writing.

The indicators of the vacuum meters should only change slightly within the next fifteen minutes, not more than 5%.

If the result of this test is positive, the vacuum lifter is tight and you can work with it without risk.

If a leak is detected even in only one vacuum circuit, the leak must be corrected immediately or the porous material replaced.



### Danger

If a leak is detected even in only one vacuum circuit, the leak must be corrected immediately or the porous material replaced. (see Chapter 8-1 Troubleshooting)

## 5-1 Working cycle

Use a shackle to secure the vacuum lifter to lifting equipment with sufficient load capacity.

Before transporting cargo, the number of suction pads must be determined on the basis of the weight of the cargo (see chapter 3-4, Front panel bottom, load capacity in dual circuit system / suction pads)



### Danger

The vacuum lines on the suction pads must be connected to the vacuum couplings on the suction frame. (see chapter 4-4 Connecting the suction pads to the vacuum circuits)

Arrange the suction pads according to the size of the cargo. If necessary, push the suckers in the carrying frame.

Switch the vacuum lifter to On using the On/Off switch. (The red flashing light begins to flash)

Determine the position of the suction frame using the geared motors and the hydraulic cylinders into which the cargo is to be gripped.

Position the vacuum lifter on the cargo.

(Observe safety information Chapter 2-9, Fig. 0-1 to 0-4)

Check that all suckers on the surface are clean and have full contact and, if necessary, press on or align a sucker that is not making contact until it is in the correct position.

If this is done, the selector switch Suction is set to On. (The red flashing light extinguishes)

During this process, the acoustic warning signal and the two red warning lamps are lit up as long as the required vacuum has not yet been reached.

Once the acoustic warning signal and the red warning lamps have extinguished, the two control lamps are lit green; a short period later, the indicators of both vacuum meters must have reached a value of approx. -0.72 bar (green range). The vacuum pumps then switch off.

After the vacuum pumps in all the vacuum circuits have switched off, the vacuum lifter is ready to lift cargo.

The cargo is guided from the side, which means that the operator stands as far as possible from the cargo in order to guide it.

The cargo is rotated and swivelled from the side. This means that the operator stands outside the area in which the cargo is rotated and/or swivelled.

Once the lifting is finished and you want to release the cargo, the selector switch Suction must be set to OFF and the release key must be activated.

If the inspection vacuum meter indicates 0, the procedure is completed and the cross arm is released from the cargo. Therefore, hold on tightly to the cargo during the release procedure.

### Note

After the lifting has been finished, switch off the device in order not to drain the battery unnecessarily.



### Danger

Goods may only be transported when the vacuum meters in both vacuum circuits have reached the minimum final vacuum of -0.72 bar (green area).

This means that the vacuum pumps in both vacuum circuits must have switched off.



### Danger

During lifting, the suction function must **NOT** be switched off



### Danger

During lifting, if the plug connection (1) on the remote control is separated.

- due to unintentional unplugging
- cable breakage or other external factors;

the acoustic warning signal sounds and the red flashing light starts to flash; set down cargo immediately und move away.

## 6-1 Care and maintenance

### 6-2 General guidelines for maintenance and servicing work

The maintenance instructions must be followed carefully and at the stipulated intervals so that the vacuum lifter functions safely and operational safety is not affected. Any visible defects on the equipment should be eliminated immediately before the DSMH is put into operation again.

Maintenance intervals can vary according to what the device is used for and to the surroundings (e.g. dust, heat, humidity, vapour) in which the vacuum lifters are used.

Any alterations, attachments and upgrades made to the vacuum lifter which could affect safety must be authorised by the manufacturer. Kappel original spare parts are to be used exclusively for repair and maintenance work. The original spare parts are appropriate for the loads and forces relevant to the vacuum lifter. Using other spare parts can lead to serious defects and to the guarantee becoming void.

### 6-3 Daily maintenance

- Clean the suction pads and/or replace them if damaged.
- Check the vacuum lines for any damage and ensure that they have a firm fit.
- Check that the fastening screws on the suction pads have a firm fit on the suction frame.
- Check that the vacuum pumps are not making any unusual noises.
- Check whether the acoustic and optical warning devices function.
- Check the charge level of the battery.
- Visual inspection of the suspension of the shackle
- Charge the batteries in the radio remote control

### 6-4 Weekly maintenance

- Visual inspection of the hydraulic lines to ensure that they are not leaking.
- Visual inspection of the vacuum lifter (see Chapter 4-5, Leak check)
- Visual inspection of the power supply
- Inspect the rotary and swivel drive to ensure that they are not making any unusual noises
- Check that the fastening screws on the swivel head, on the suction frame and on the vacuum lifter
- Relubricate the articulated lug on the hydraulic cylinders and the bolts on the pivot bearings.  
(For suitable lubricants, see track system swivel head, see Chapter 6-13)

### 6-5 Monthly maintenance

- Relubricate the track and the links on the swivel head  
(see Chapter 6-13)

## 6-6 Maintenance after 12 months

- Check all bearing parts to ensure that they are not deformed
- Check that there are no cracks in the upper frame
- Check that there are no cracks in the suction frame
- Check that there are no cracks in the suspension
- Check that no unusual noises coming from the vacuum pumps
- Check that the acoustic and optical warning devices are functioning
- Check that the rotary and swivel drive are not making any unusual noises
- Check that there are no cracks in the swivel head
- Check the bearing clearance of the swivel head
- Check the electrical equipment for any wear and tear or defective insulation
- Check the vacuum lines and screw connections.
- Check the suction pads for any damage



### Danger

Please note that the trades association requires an annual inspection of vacuum lifting devices by a specialist, in accordance with the accident prevent regulations (VbG 9a-prEN 13155:1998). All periodic inspections are to be conducted by the operator.

We offer annual maintenance for the inspections stipulated by the trade association on our premises or your premises. The inspection carried out by us includes an inspection of the load capacity of the individual suckers. Please contact us for details.

## 6-7 Suction pads

If it is necessary to clean the goods to be transported, use a fat solvent that evaporates **without any residue** such as Nitro or brake-cleaner.

The surface must **not** be cleaned with glass-cleaner, detergent or similar.

Always ensure that the suckers are not placed on sharp edges because this could damage the sucker lips. This would lead to leaks in the suction circuit, impairing the functioning of the device.

Never place the machine with mounted suckers with the rubber surfaces of the suckers on sandy or similar ground. This could damage the sealing lips of the suckers. This would lead to leaks in the suction circuit, impairing the functioning of the device. Or the grains of sand or similar substances could be pressed into the rubber surfaces, leading to damage to the upper surface of the transported goods.

## 6-8 Vacuum pumps

The vacuum obtained must be constantly monitored on the vacuum meters. If the minimum final vacuum of approx. -0,72 bar is no longer obtained, the vacuum lifter must no longer be used.  
Possible causes for not obtaining the final vacuum (see Chapter 8-1 Troubleshooting)



### Danger

If the vacuum lifter no longer reaches the minimum final vacuum of -0,72 bar, it is no longer able to lift the specified load.

## 6-9 Geared motors

Maintenance-free

## 6-10 Hydraulic pump with hydraulic cylinder

Maintenance-free

## 6-11 Radio remote control



### Caution

The batteries in the radio transmitter should always be charged before the device is used.

## 6-12 Battery

If the vacuum lifter is not used for a long period, the battery must be charged at least once a week in order to avoid deep discharge.

## 6-13 Swivel head

The swivel head is provided with lithium complex soap grease in the factory on a mineral oil basis with EP additives in accordance with DIN 51825, KP2P-20.

When relubricating, the same lubricant should, be used as the one already in the swivel head, if possible. If other lubricants are used, please ensure that they are compatible with the first lubricant and with the sealing material. If in doubt, please consult the manufacturer of the lubricant.

- Clean lubrication nipple before lubricating
- During the lubrication process, turn the swivel head slowly.
- Refill grease until it forms a fresh grease collar on the bearing gaps and/or seals
- Examples of lubricants for track and links are found in the following table.

Supplier	Track system	Links
ARAL	Aralub HLP2	Aralub LFZ1
BP	Energrease LS-EP2	Energol WRL/GR 154 GS
CASTROL	Grease LMX	
ESSO	Beacon EP2	Surret Fluid NX
SHELL	Calithia EP2	Malleus Fluid D

## 7-1 Technical data

Manufacturer:	Kappel Flachglastechnik GmbH Schlachthofstrasse 3-5 87700 Memmingen Germany Tel: +49 (0) 8331/4487 Fax: +49 (0) 8331/82962 E-mail : <a href="mailto:info@vakuumlifter-kappel.de">info@vakuumlifter-kappel.de</a> Internet : <a href="http://www.vakuumlifter-kappel.de">www.vakuumlifter-kappel.de</a>
Designation:	Vacuum lifter (battery operated)
Type:	DSMH2-12V
Serial number:	<u>2276</u>
Year of construction:	<u>2017</u>
Operating instructions:	Art. No.: KA-DSMH2-12V-15.5.17
<u>Temperature range</u> Storage temperature	+1 to +40 degrees Celsius (ambient) room temperature, not below 0 degrees
<u>Dead weight</u>	see type plate on device
<u>Vacuum supply</u> <u>Hose connection</u>	0.75 litre / vacuum circuit 6 mm
<u>Two vacuum pumps</u> Supply voltage: Nominal current	12V, DC approx. 4A / pump
<u>Two batteries</u> Nominal voltage: Nominal capacity:	12V, DC approx. 26 Ah
<u>Mains operation</u> Mains voltage: Mains frequency:	115 / 230V, AC 50/60 Hz
<u>Rotary drive</u> Geared motor	12V / 96W
<u>Swivel drive</u> Hydraulic pump	12V / 150W

## 7-2 Measurements of the DSMH2-12V

Fig. 11

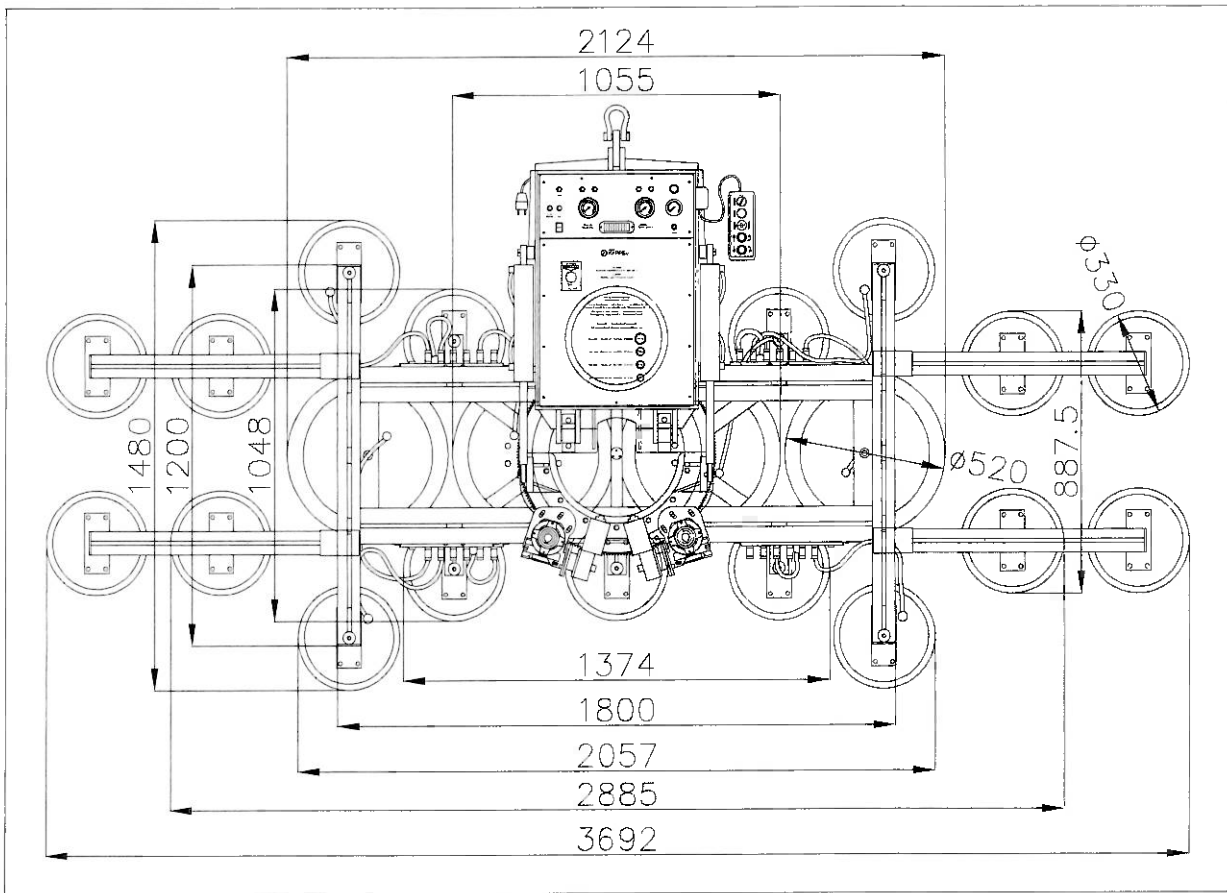
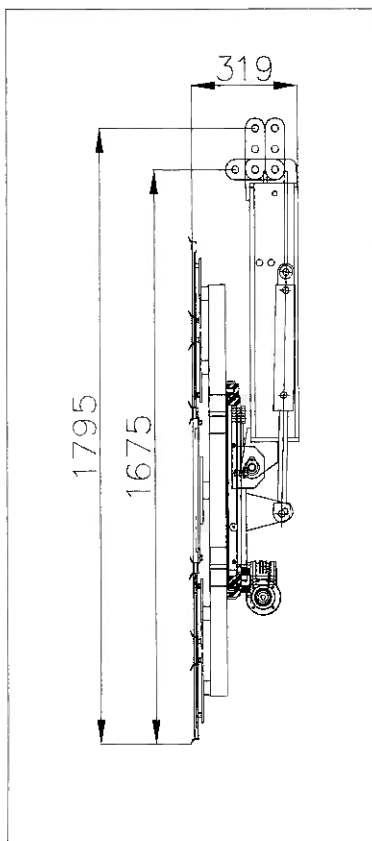

Fig. 12





### 7-3 Tragfähigkeit, WLL des DSMH2-12V

Maximum load capacity = WLL = Working Load Limit (see type plate)

Permitted load capacity = Depends on type and quantity of suction pads attached.  
(see Chapter 3-4)



#### Danger

The load capacity indicated on the type plate on the device refers to the maximum load capacity of the vacuum lifter.

The permitted load capacity of the vacuum lifter **must always** be calculated by means of the load capacity in the dual circuit system / suction pads and therefore depends on the number and the type of the suction pads attached

The operator is obliged not to exceed the load of the suction pads attached and the maximum load capacity of the vacuum lifter.

All specifications relating to the load capacity refer to an even surface load.  
Furthermore, all suckers must also have gripped the goods to be transported.

#### Sucker type 400 K

Diameter: 520 mm  
Load capacity on smooth, clean, dry surface with 60% vacuum  
Vertical: 400 kg  
Horizontal: 400 kg  
Horizontal 400K in dual circuit system 200kg / suction pad

#### Sucker type 150 K

Diameter: 330 mm  
Load capacity on smooth, clean, dry surface with 60% vacuum  
Vertical: 150 kg  
Horizontal: 150 kg  
Horizontal 150K in dual circuit system 75kg / suction pad

#### Sucker type 388 K

Diameter: 290 mm  
Load capacity on smooth, clean, dry surface with 60% vacuum  
Vertical: 100 kg  
Horizontal: 100 kg  
Horizontal 388K in dual circuit system 50kg / suction pad

#### Sucker type 540 K

Diameter: 220 mm  
Load capacity on smooth, clean, dry surface with 60% vacuum  
Vertical: 50 kg  
Horizontal: 50 kg  
Horizontal 540K in dual circuit system 25kg / suction pad

### 7-4 Maximum size of the plate material to be transported

The maximum size of the plate material to be lifted depends on the size of the suction frame attached and on the suction pad.

The cargo may only go 0.5m over the outer edge of the suction pad.

Example (see Fig.11)

Outer edge of: max. width = 3.692m max. height = 1.48m

The maximum size of the cargo in this case would be: Width = 4.692m height = 2.48m

# 7-5 Wiring diagram of the DSMH2-12V

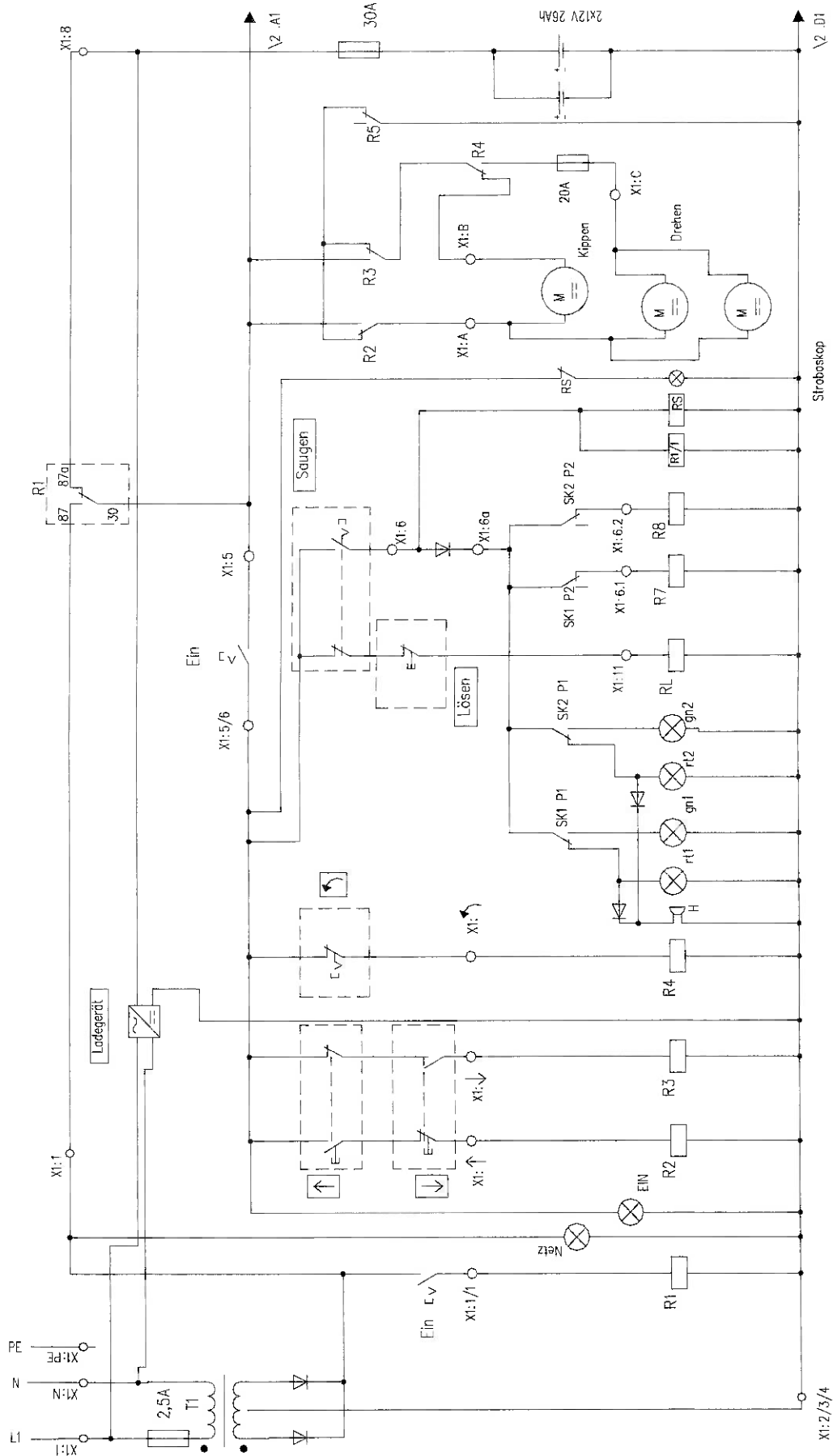

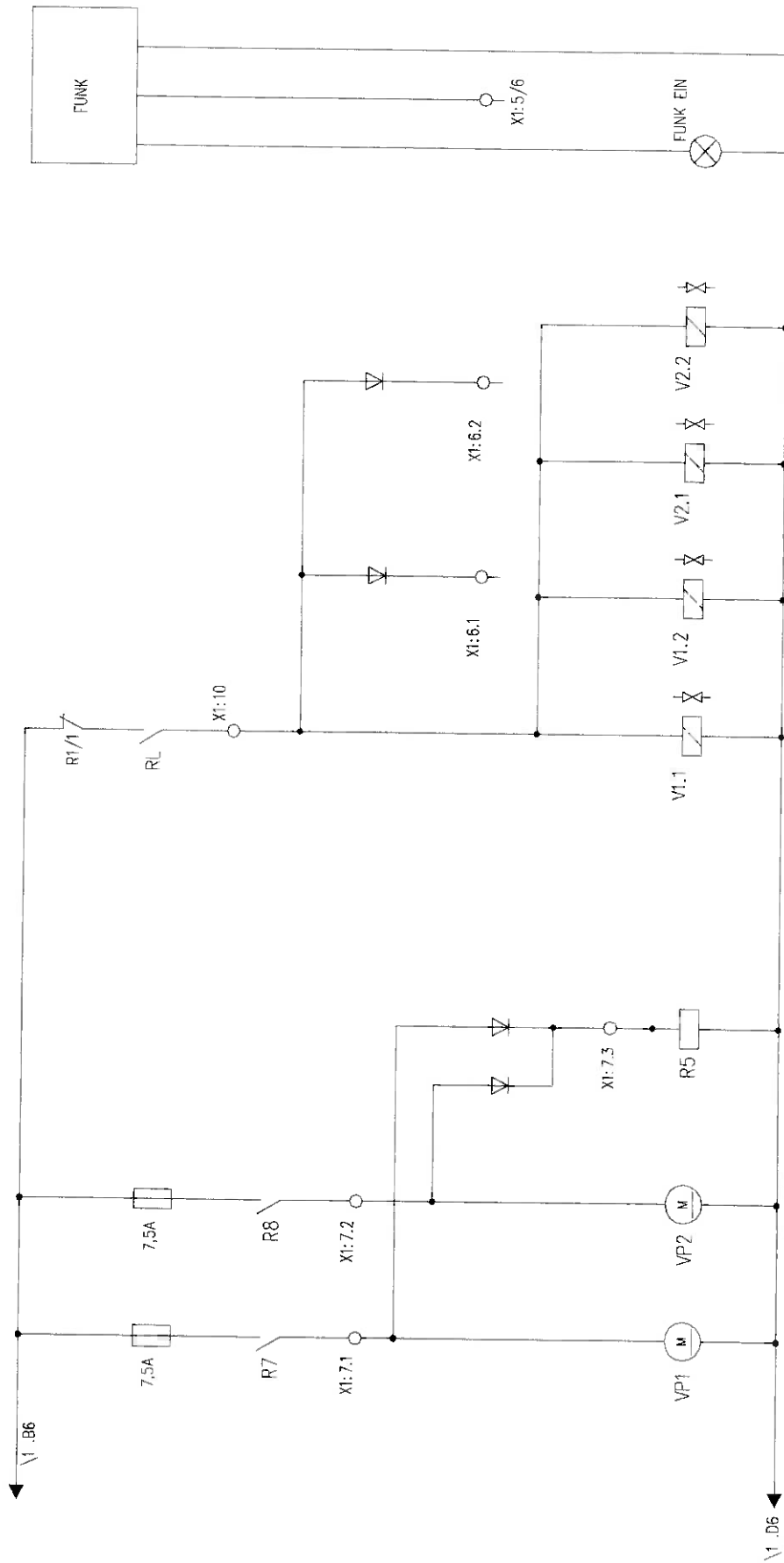

## 8-1 Troubleshooting, remedies

Defect	Cause	Remedy
no warning signals	vacuum above -0.65bar	device in order
	vacuum switch defective	contact customer service
	signal tone defective	replace
	warning lamp red defective	replace
vacuum pumps do not switch on suckers are switched on	flashing light defective	replace
	battery empty	operate device with mains supply charge battery
	battery defective	replace
	vacuum switch defective	contact customer service
	relay fuse in upper frame R7 or R8 defective	replace
	vacuum pump defective	contact customer service
vacuum pump does not switch off when -0.72bar is reached	batteries in remote control empty	recharge
	vacuum switch defective or switch point moved	contact customer service
vacuum pumps no longer reaches minimum final vacuum of approx.-0.72 bar	A suction pad is no longer properly on	correct the suction pad or press
	suction pad defective	replace
	vacuum line defective	replace
	vacuum coupling defective	replace
	screw connection defective	replace
	magnetic valve defective	contact customer service
a leak is discovered during leak check	vacuum pump defective	contact customer service
	suction pad defective	replace
	vacuum line defective	replace
	vacuum coupling defective	replace
	screw connection defective	replace
mains operation not possible	leak in built-in parts in upper frame	contact customer service
	safety cutout in upper frame defective (2,5A)	replace
rotation not possible	mains connection defective	have checked by an expert
	Vacuum pumps are active	Wait until all vacuum pumps switch off
	emergency off pressed	switch on
swivelling not possible	safety cutout in upper frame defective (20A)	replace
	vacuum pumps are active	wait until all vacuum pumps switch off
	emergency off pressed	switch on
plate material falls off during lifting	load capacity too high	determine weight of cargo and compare with built-in suction pads
	cargo or suction pad wet	dry off
	cargo oder suction pad soiled	clean
	suction pad are covered by protective hood	remove
	suction pad defective	replace
	vacuum hose bent	alter hose routing and/or replace vacuum hose
	vacuum lines are not connected to the vacuum couplings	connect

## 9-1 Spare parts / Spare parts order

Please fill in the following identification data of your vacuum lifter so that they are always to hand. This will enable you to obtain the correct spare parts.

Vacuum lifter – type : .....

Serial no. : .....

Construction year : .....

Load capacity : .....

Original spare parts can be ordered at the following address.

Kappel Flachglastechnik GmbH  
Schlachthofstrasse 3-5  
87700 Memmingen  
Germany  
Tel: +49 (0) 8331/4487  
Fax: +49 (0) 8331/82962  
E-mail: [info@vakuumlifter-kappel.de](mailto:info@vakuumlifter-kappel.de)  
Internet: [www.vakuumlifter-kappel.de](http://www.vakuumlifter-kappel.de)



# Daily Pre-Use Checklist

## Vacuum Lifter

Northern (Head Office) Tel: +44 (0)1482 227333

Central Tel: +44 (0)1302 341659

Western Tel: +44 (0)1384 900388

Southern Tel: +44 (0)203 174 0658

www.hird.co.uk

Machine Model: <b>Kappel Hydraulica 1500</b>		Site Name:
Date Week Commencing:	Fleet No:	Address:
Inspected by:		

### Daily Pre-use Checks

		M	T	W	T	F	S	S	COMMENTS
1	Are all operators manuals present and readable								
2	Is the Report of Thorough Examination (LOLER) in date								
3	Complete a visual walk around / Inspection for any noticeable defects								
4	Are all safety information decals present and readable								

### Check the following components or areas for damage, or missing parts & unauthorised modifications:

5	Is the lifting attachment free from defects and safe to use								
6	Vacuum pads for rips, tears, quality and cleanliness								
7	Vacuum pipes and connections (in particular quick release fittings)								
8	All extension arms are present and free from defects (where applicable)								
9	Make sure all individual pad shut off valves are open (where applicable)								
10	Electrical components, wiring, connectors,								
11	Check input mains voltage corresponds with charger voltage (110v or 240v)								
12	Charger								
13	Check battery has sufficient charge								
14	Are rotation and tilting movements functional								
15	Check handles security								
16	Check remote for any damage or defects (where applicable)								
17	Check operation buttons / switches are working and free from defects								
18	Energise vacuum on non porous surface								
19	Are lights and audible alarms on during vacuum process								
20	Does the vacuum reach sufficient level, before switching off (see gauges)								
21	Does battery gauge illuminate when pump switches off <b>If NO - DO NOT USE</b>								
22	Check Safe Working load of vacuum - is it suitable for the proposed load								
23	Carry out full function test								

Is the machine safe to use? (please circle)	YES	YES	YES	YES	YES	YES	YES	
	NO	NO	NO	NO	NO	NO	NO	
Operator's Initials								

Result of Inspections: List defects or state "No Defects"

Signature:	Name:	Date:
------------	-------	-------