

**HIRD**  
**GLASS**

[www.hird.co.uk](http://www.hird.co.uk)

## OPERATOR MANUAL

# KAPPEL HYDRAULICA 1000

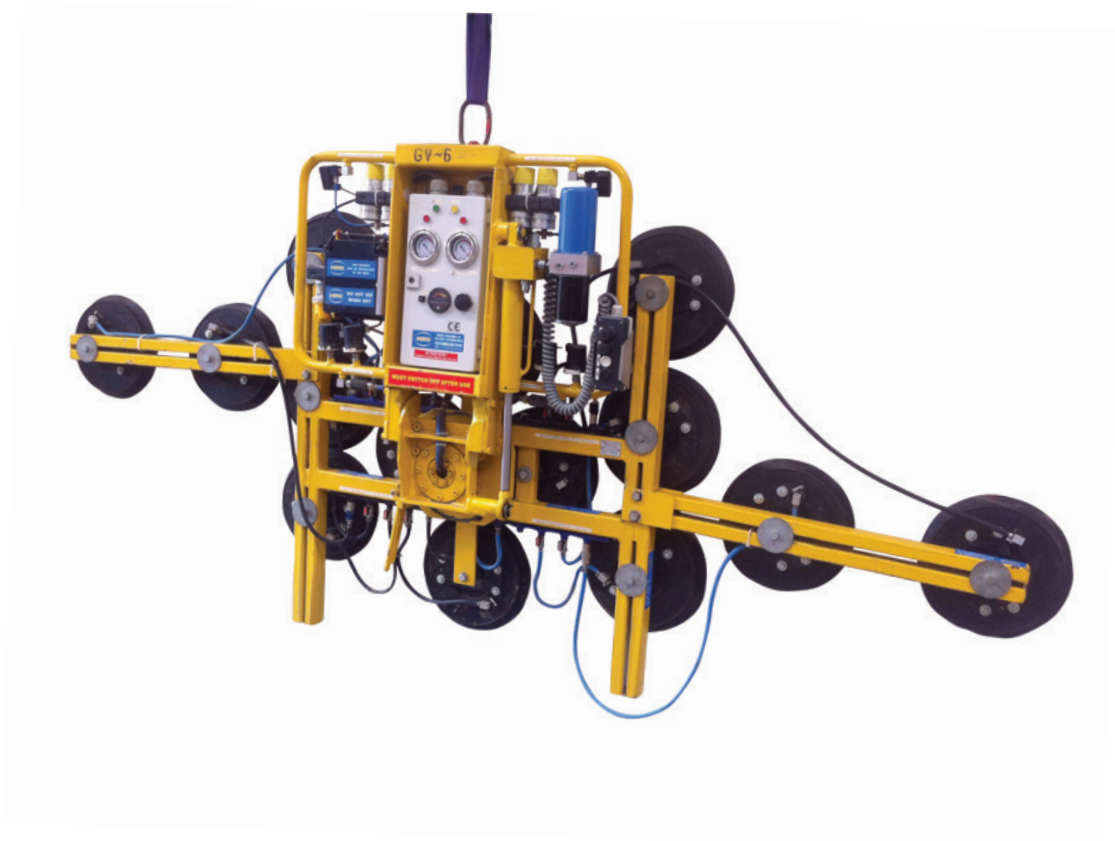

**Northern** (Head Office)  
Tel: +44 (0)1482 227333

**Central**  
Tel: +44 (0)1302 341659

**Western**  
Tel: +44 (0)1384 900388

**Southern**  
Tel: +44 (0)203 174 0658

## Contents

Forward	1-1
Technical data	1-2
Basic safety information	2-1
Warning instructions and symbols	2-1
Authorised use	2-1
Organisational measures	2-2
Personnel selection and qualifications	2-3
Safety instructions regarding particular operating stages	2-3
Normal operation	2-3
Special work	2-4
Safety instructions for special types of danger	2-4
Electrical energy	2-4
Oils, greases and other chemical substances	2-4
Commissioning	3-1
Charging the batteries	3-2
The remote control	3-3
Before transporting	3-4
Operation	4-1
Switching on	4-2
Working cycle	4-3
Switching off	4-6
Charging the battery	4-6

<b>Troubleshooting</b>	<b>5-1</b>
Pumps no longer perform correctly	5-1
Leak check	5-2
Leak check for the entire system	5-2
Leak check without sucker	5-2
Electrical malfunction	5-3
Vacuum pumps do not start when the device is actuated	5-3
Vacuum pumps do not switch off when vacuum of -0.72 bar is reached	5-3
No warning signals	5-3
Rotating cannot be carried out	5-4
Swivelling cannot be carried out	5-4
<b>Maintenance</b>	<b>6-1</b>
The suckers	6-1
The vacuum lines	6-1
Leak check	6-2
The geared motor	6-3
The hydraulic pump with cylinder	6-3
The vacuum pump	See appendix
<b>Technical data</b>	<b>7-1</b>
Performance data of the DSMH2-12V	7-2
Wiring diagram of the DSMH2-12V	7-3
<b>Spare parts list</b>	<b>8-1</b>
Test report suction pad 388/K	See appendix

## Foreword

These operating instructions are intended to help you become familiar with the DSMH2-12V and to use it as intended.

These operating instructions contain important instructions about operating the DSMH2-12V safely, effectively, and economically. Observing them helps to avoid repair costs and down time and to increase the reliability and working life of the DSMH2-12V.

These operating instructions must be supplemented by additional instructions due to existing national accident prevention regulations.

These operating instructions must always be available at the site of use of the DSMH2-12V

These operating instructions must be read and observed by every person responsible for doing work on the DSMH2-12V, for example:

- operation, including equipping, troubleshooting during operation, removal of production waste, care
- maintenance (servicing, inspection, repair) and/or
- transport.

In addition to the operating instructions and binding accident prevention regulations applicable for the country of use and the application case, the recognised technical rules for safe and professional work must also be observed.

If you discover errors when reading these operating instructions, or if you have further comments or suggestions, please contact:

Kappel Flachglastechnik GmbH  
Schlachthofstraße 3-5  
87700 Memmingen

The management appreciates your cooperation.

## Technical description

The DSMH2-12V is a combination of four vacuum pumps with power supply (battery or mains, including charger) and a vacuum cross arm with two vacuum circuits working independently from each other. This vacuum cross arm has twelve suction pads and is intended for flexible use on construction sites, at various crane systems, etc., anywhere where no 220 to 240 volt connection is available. Using the DSMH2-12V, the transported goods can be rotated 360 degrees and also be swivelled 90 degrees hydraulically. The rotation and swivelling movement is operated by remote control with a cable. The DSMH2-12V is hung on a crane hook and is supplied with energy via the installed batteries. In addition to easy installation on a crane or similar device, the DSMH2-12V also offers the safety advantage that in general no vacuum supply hose or voltage supply line is required as is the case with separated devices (cross arm, vacuum pump). In addition, it is also possible to lower transported goods during a power outage with this type of device as long as the vacuum circuit is perfectly sealed, because the vacuum reserve tank is located on the vacuum cross arm.

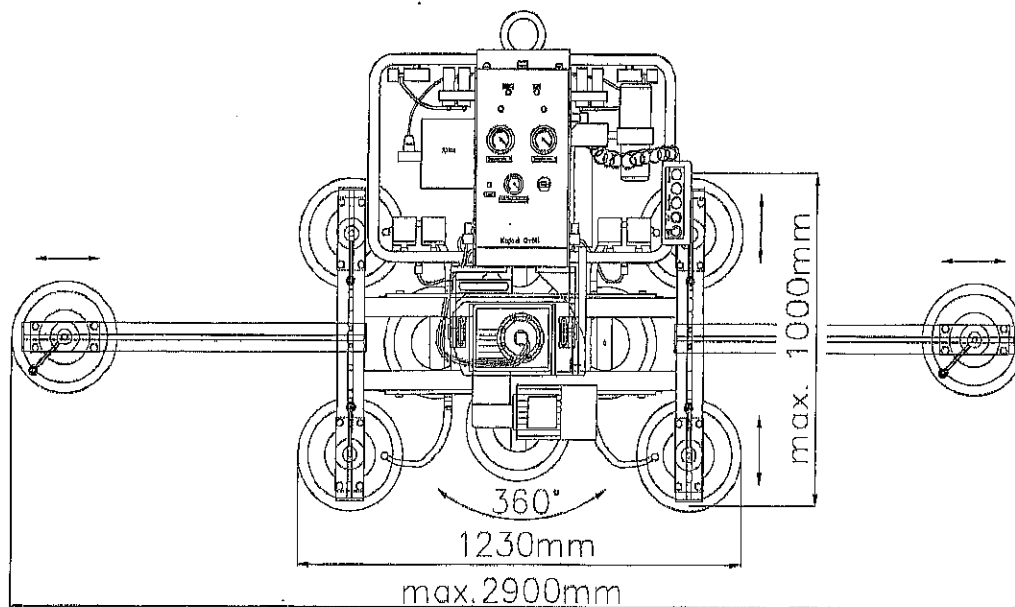

In detail, the device consists of a round pipe frame with suspension eye, this basic frame simultaneously forms the two vacuum reserve tanks and holds the vacuum pumps, the battery loading device, the hydraulic cylinder with pump and the batteries. A second rectangular pipe frame is connected to this basic frame first via a swivelling joint and then via a rotating joint. This frame is the carrier frame on which the geared motor and the suckers are mounted. The sucker connections are supplied with a vacuum (suction) or normal compressed air (releasing) by means of the magnetic valves (suction/release valves) of the two vacuum circuits. The suckers (six per vacuum circuit) can be blocked individually using stop valves. Two inspection vacuum meters provide information on the exact pressure ratios in the vacuum lines to the individual suckers. A voltage display indicates the battery charge level.

The charging circuit voltage for the charger is 220-240 volt AC (50/60 Hz).

Four vacuum pumps are used to generate the vacuum (two vacuum pumps per vacuum circuit). The vacuum pumps work without oil lubrication and are therefore maintenance-free.

In order to avoid draining the batteries unnecessarily, the pump switch has a two-point controller that switches off the vacuum when the pressure reaches -0.72 bar in the vessel, switches the pumps off and switches the pumps back on when the pressure falls below approx. -0.68 vacuum. This avoids premature draining of the batteries due to the pumps being allowed to run unnecessarily. The batteries are maintenance-free and enclosed; they are totally discharge-safe.

### Mode of operation

Switch the machine on using the ON/OFF switch. Then set the two magnetic suction/release valves to RELEASE using the remote control. The vacuum cross arm must be positioned on the load to be transported in such a way that all suckers are flat on the smooth clean surface so that the sucker lips can seal completely. Set both suction/release valves to SUCTION using the remote control and wait until the pumps of both vacuum circuits switch off. You can check the vacuum using the vacuum meters 1 and 2 on the device. If there is a vacuum of -0.72 bar in both vacuum circuits, the load can be transported. To release the suckers from the load, set the two suction/release valves to RELEASE.

### Attention

The DSMH2-12V must **never** be commissioned when there is only **one** functioning vacuum circuit.

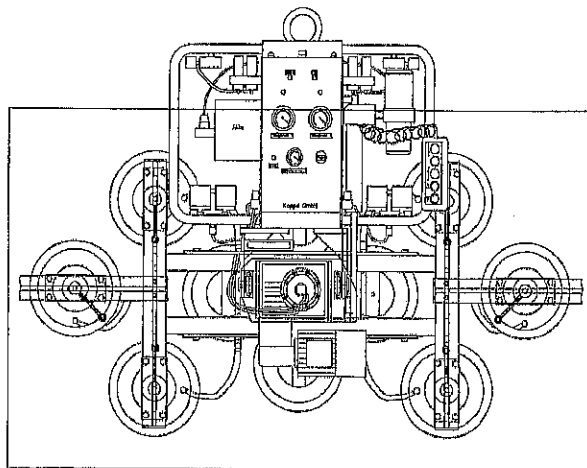
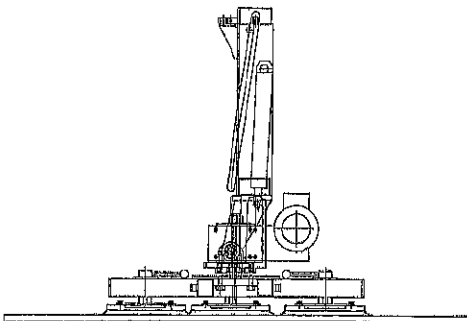

## Basic safety information

### Warning instructions and symbols

The following terms and symbols are used in the operator's manual for especially important information:

- Note** Special information regarding the economical use of the device
- Caution** Special information regarding requirements and prohibitions for preventing damage.
- Danger** Information or requirements or prohibitions for protecting people or preventing extensive damage.

### Authorised use

The DSMH2-12V has been constructed in accordance with the state of the art and recognised safety regulations. Nevertheless, its use may result in danger to life and limb of the operator or third parties and impairment of the machine or other property may occur.

The machine may only be used when in technically perfect condition, as authorised. The user must be conscious of safety and risks and act in accordance with the instructions. Failures which can interfere with safety must be eliminated immediately.

The DSMH2-12V is exclusively for transporting gas-tight, dry materials with firm, flat surfaces. Other use or use going beyond this, for example transporting gas-permeable materials, film-covered materials, wet materials, or rotating or swivelling large or heavy transported goods is not authorised. The manufacturer/supplier is not liable for the damages resulting from this. The user bears the risk alone.

Use as authorised use also includes complying with the operating instructions and the inspection and maintenance conditions.

## Organisational measures

Always keep the operating instructions within reach at the site of use.

In addition to the operating instructions please observe and teach any other generally applicable statutory regulations concerning accident prevention.

Such obligations can also include providing and wearing personal protective equipment.

Please supplement the operating instructions with instructions including supervision and reporting obligations taking into consideration operational corporate circumstances, e.g. relating to work organisation, work processes, personnel used.

The personnel authorised to operate the device must read the operating instructions, particularly the chapter about safety instructions before starting work. It is too late to read the instructions if work has already been started. This applies in particular to personnel who only work on the machine occasionally, e.g. for equipping it and carrying out maintenance work.

Occasional checks should be carried out to ensure that the members of personnel follow the instructions and work in a safety-conscious manner and are aware of risks.

If necessary or if required by regulations, personal protective equipment should be used. Glass should only be transported with the appropriate protective equipment (safety shoes, protective gloves, wrist protectors, helmet etc.) A helmet should be worn at all times when transporting goods above head height.

All safety and danger instructions on the device should be complied with.

All safety and danger instructions on the device should be kept complete and in legible condition.

If there are any safety-related changes to the device or its operation, the device should be stopped immediately and the malfunction should be reported to the relevant office or person.

No changes, attachments or upgrading work that could possibly impair safety should be carried out on the machine without the consent of the supplier. This also applies to the installation and setting of safety equipment and valves as well as to welding on load-bearing parts.

Spare parts must fulfill the technical requirements specified by the manufacturer. This is always guaranteed with original replacement parts.

Vacuum hose lines should be replaced at the specified intervals or at appropriate intervals, even if there are no recognisable safety defects.

Compulsory deadlines or those specified in the instructions for recurring tests / inspections should be complied with

Appropriate workshop equipment is absolutely necessary for performing the maintenance measures.



## Personnel selection and qualification

Work on/with the machine may only be performed by reliable personnel. The legal minimum working age should be observed.

Use only trained or instructed personnel; responsibilities among personnel should be clearly established for operation, equipping, maintenance, and repair.

Ensure that only authorised personnel works on the machine.

Specify a person who is responsible for operating the machine and give him/her the opportunity to refuse to comply with the safety instructions of third parties.

Personnel being trained or instructed, or who are taking part in a general training programme, may only work on the machine when under the constant supervision of an experienced person who is familiar with this situation.

Work on the electrical equipment of the machine may only be performed by an electrician or by trained personnel under the direction and supervision of an electrician in accordance with the rules of electrical engineering.

## Safety instructions on particular operating phases

### Normal operation

Avoid all unsafe work practices.

Before starting work, become familiar with the working environment at the site of use. The working environment includes impediments in the work and traffic area, the load bearing capacity of the floor, and cordoning off the worksite from public traffic areas.

Take measures to ensure that the machine is only operated when safe and functional.

Check the machine for externally recognisable damages and flaws at least once per shift. Report any changes that occur (including those to the operating behaviour) immediately to the responsible office/person. If necessary, stop the machine immediately and secure it!

During malfunctions, the machine should be stopped immediately and secured. Malfunctions should be corrected immediately.

The switching on and off procedures should be complied with, and the inspection displays should correspond to the operating instructions.

Always stop work if it becomes dark or if visibility is poor!

## **Special work**

The setting, maintenance, inspection activities and deadlines, including information on replacement of parts and modules stipulated in these operating instructions must be observed. These activities may only be performed by authorised specialists.

Only perform maintenance and repair work when the machine is positioned on flat ground with sufficient bearing capacity and is secured so that it cannot roll away or collapse.

Clean machines, particularly connections and screw connections at the beginning of maintenance/repair work. Do not use aggressive cleaning agents! Use lint-free cloths for cleaning.

Never clean the machine with water or steam jet (high-pressure cleaner).

After cleaning, inspect all vacuum lines for leaks, loosened connections, abrasion and damage. Repair any flaws immediately!

Always tighten screw connections loosened during maintenance and repair work.

## **Safety instructions for special types of danger**

### **Electrical power**

Use only original fuses with the specified current strengths. Switch off the machine immediately during malfunctions to the electrical energy supply.

Work on electrical equipment or operating materials may only be performed by an electrician or by trained personnel under the direction and supervision of an electrician in accordance with the rules and regulations of electrical engineering.

Machine and system parts on which inspection, maintenance, or repair work must be performed, must be switched free of current if required. First check the switched off parts to ensure that they are free of voltage, then ground and short-circuit them, and insulate neighbouring live parts.

The electrical equipment of the machine must be checked regularly. Flaws such as loose connections and melted cables must be repaired immediately.

### **Oils, greases, and other chemical substances**

Observe the safety regulations applicable for the product when using oils, greases, and other chemical substances!

## Commissioning

### Note

- Do not store the DSMH2-12V in a damp or very cold (frost) environment. Otherwise there is no guarantee that the installed pumps will function properly.
- Rotation and swivelling can only be carried out when the pumps in both vacuum circuits are switched off.
- Swivelling can only be carried out when the DSMH2-12V is hanging from a crane hook or similar, i.e. the hydraulic pump is in a vertical position.

### Caution

- Always ensure that the suckers are not placed on sharp edges because this could damage the sucker lips. This would lead to leaks in the suction circuit, impairing the functioning of the device.
- Never place the machine with mounted suckers with the rubber surfaces of the suckers on sandy or similar ground. This could damage the sealing lips of the suckers. This would lead to leaks in the suction circuit, impairing the functioning of the device. Or the grains of sand or similar substances could be pressed into the rubber surfaces, leading to damage to the upper surface of the transported goods.

### Danger

- Do not allow heavy rain to fall on the DSMH2-12V.
- Do not place the DSMH2-12V in water.
- Do not convey loads over persons or machines. Cordon off the area under hanging transported goods with wide clearance.

## Charging the battery

Check the DSMH2-12V for any externally recognisable damages or flaws.

Compare the connection on the power supply network and check the voltage, current and mechanical connection (plug connection) with the necessary data for the vacuum pumps. If they do not correspond, the machine may not be operated.

Connect the DSMH2-12V to the supply network (9) using an extension cable.

The charging procedure can be checked in voltage display (13) after pressing the test (12) button.

After the charging procedure is completed, a value of 100% must be visible in the voltage display (13) when Test button (12) is pushed.

The battery (20) is charged after a maximum of 12 hours.

Remove the extension cable from the supply network.

This completes the loading procedure.

### Note

After the transporting work is completed, switch the device off with the switch (10) in order not to drain the battery unnecessarily.

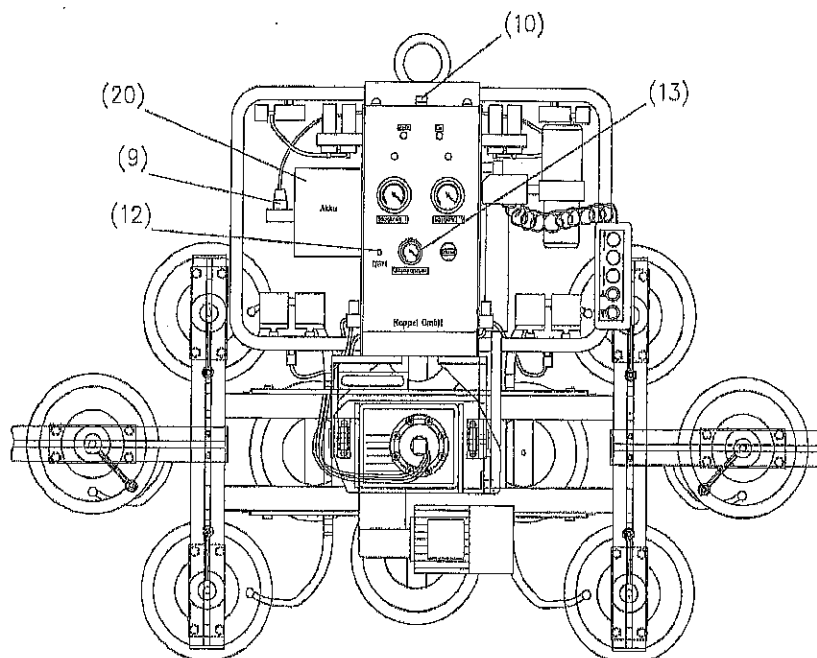

The remote control

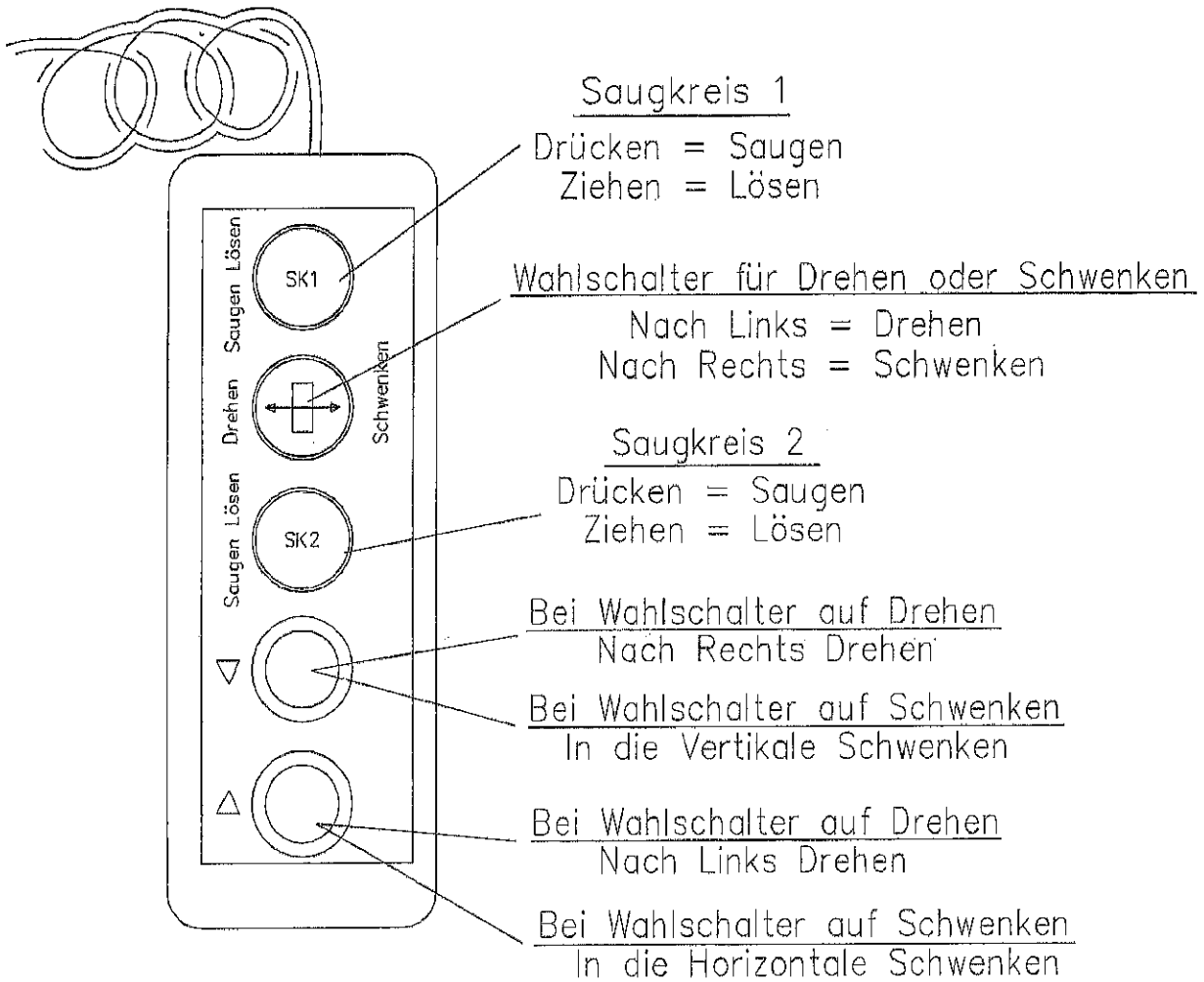

## Before transporting

Check the DSMH2-12V for any externally recognisable damage or flaws.

Hang the DSMH2-12V from the suspension eye (1) on a crane hook or similar device.

Then set the two magnetic suction/release valves (2.1 and 2.2) to the RELEASE position.

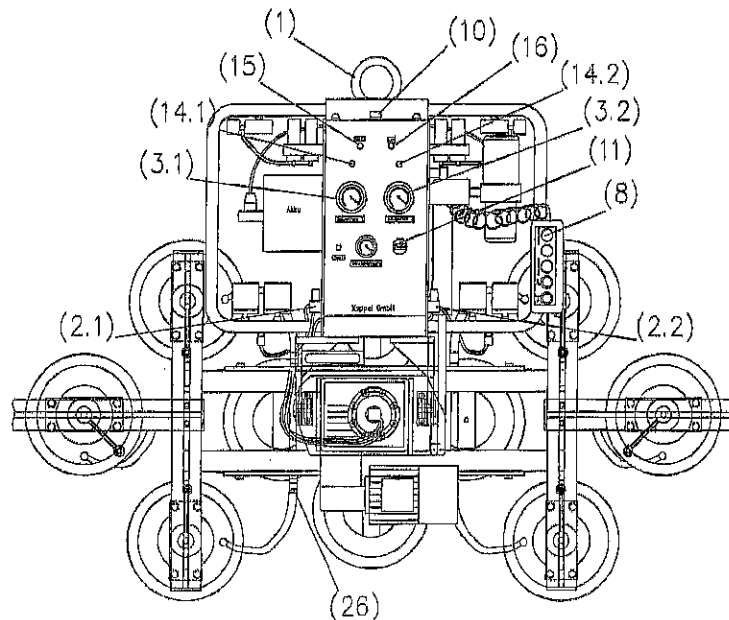

Switch the machine to ON using the on/off switch (10). The pumps must start up if the vacuum is insufficient. The Pump indicator light (16 yellow) indicates that the pumps are ready for operation. If this is not the case, working with the DSMH2-12V is not permitted (see Troubleshooting).

The two vacuum indicator lamps (14.1 and 14.2 red) and the signal tone (11) signalise insufficient vacuum in the lines to the suckers. These signals depend on the vacuum in the reserve tanks. The existing vacuum in the suction frames of both vacuum circuits can be checked on the two vacuum meters (3.1 and 3.2).

After a short time, a vacuum of at least -0.65 bar should have built up in each tank. The vacuum pumps switch off when -0.72 bar vacuum is reached. This should be the case after a short time.

In order to check the vacuum, set the suction/release valves (2.1 and 2.2) to RELEASE using the remote control (8). This condition must be fulfilled. The individual suckers (six per vacuum circuit) must be blocked from the vacuum reserve tanks using stop valves (26). The indicators of the two inspection vacuum meters (3.1 and 3.2) must then be in the green area. Then switch the device switch (10) off and wait ten minutes. During this time the indicators of the two inspection vacuum meters (3.1 and 3.2) may not move.

If only one indicator changes, the DSMH2-12V is leaking and may no longer be used until the error has been corrected. However, if this is not the case, the DSMH2-12V is ready for operation after the machine switch (10) has been switched on and the two suction/release valves (2.1 and 2.2) have been reset to RELEASE using the remote control.

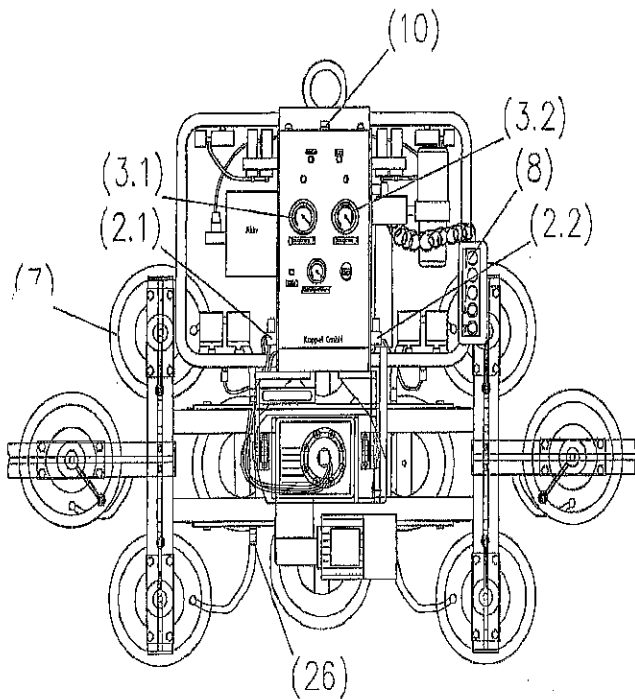

The individual suckers (7) must be connected to the vacuum reserve tanks by opening the blocking valves (26).

In order to check the tightness of the hose lines and the individual suckers (7), either a larger plate or several smaller plates of a gas-impermeable material must be present. These plates are held on the individual suckers and then sucked on. To do so, the suction/release valves (2.1 and 2.2) must be set to SUCTION using the remote control. A vacuum of at least  $-0.65$  bar should build up immediately in each vacuum circuit. If this happens, the machine switch (10) must be switched off. Read the achieved vacuum from the inspection vacuum meters (3.1 and 3.2) and compare it with a reading taken about 15 minutes later. If there is no discrepancy, the device is leak-tight and safe to operate. If a discrepancy of more than 5% occurs, the DSMH2-12V must be checked to find the leak (see Troubleshooting).

Commissioning is complete once the machine switch (10) has been switched back on.

#### Caution

The DSMH2-12V must **NEVER** be commissioned with only **one** functional vacuum circuit.

## Commissioning

### Note

- Do not store the DSMH2-12V in a damp or very cold (frost) environment. Otherwise there is no guarantee that the installed pumps will function properly.
- Rotation and swivelling can only be carried out when the pumps in both vacuum circuits are switched off.
- Swivelling can only be carried out when the DSMH2-12V is hanging from a crane hook or similar, i.e. the hydraulic pump is in a vertical position.

### Caution

- Always ensure that the suckers are not placed on sharp edges because this could damage the sucker lips. This would lead to leaks in the suction circuit, impairing the functioning of the device.
- Never place the machine with mounted suckers with the rubber surfaces of the suckers on sandy or similar ground. This could damage the sealing lips of the suckers. This would lead to leaks in the suction circuit, impairing the functioning of the device. Or the grains of sand or similar substances could be pressed into the rubber surfaces, leading to damage to the upper surface of the transported goods.

### Danger

- Do not allow heavy rain to fall on the DSMH2-12V.
- Do not place the DSMH2-12V in water.
- Do not convey loads over persons or machines. Cordon off the area under hanging transported goods with wide clearance.



## Switching on

Set the two suction/release valves (2.1 and 2.2) to RELEASE using the remote control.

Switch on the machine with the switch (10). The pumps must start up if the vacuum is insufficient. The pump indicator light (16 yellow) indicates that the pumps are active. If this is not the case, working with the DSMH2-12V is not permitted (see Troubleshooting). The two vacuum indicator lights (14.1 and 14.2 red) and the signal tone (11) indicate insufficient vacuum. These signals depend on the vacuum in the reserve tank.

If the DSMH2-12V is operated in mains operation mode, this is indicated via the network indicator light (15 green).

After a short period, a vacuum of at least  $-0.65$  bar should have built up, both vacuum indicator lights (14.1 and 14.2 red) and the signal tone (11) should go out. The vacuum pumps switch off when approx.  $-0.72$  bar is reached. This should be the case after a short time.

As long as no transported goods are sucked on and the stop valves (26) on the frame to the suction pads are closed, it is not possible to check the vacuum from the two inspection vacuum meters (3.1 and 3.2).

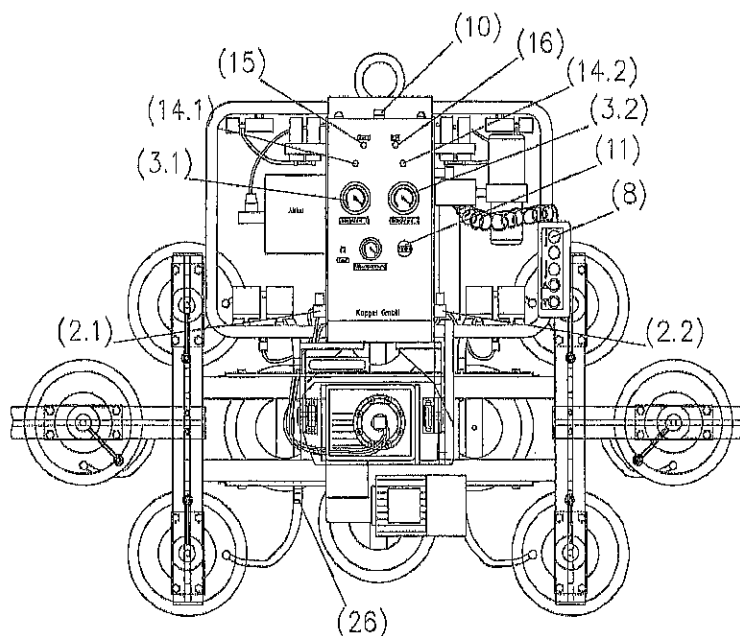

## Working cycle

Arrange the suckers (7) according to the size of the transported goods. If necessary, loosen the clamping lever (6) and offset the suckers (7) in the carrier frame (5), tighten the clamping lever (6).

Determine the position of the carrier frame (5) using the geared motor (41) and the hydraulic cylinder (42) using the remote control, in which the transported goods are to be sucked on (see page 3-3 remote control).

Position the DSMH2-12V on the goods to be transported

## Note

- Rotating and swivelling can only be carried out if the pumps of both vacuum circuits are switched off.
- Swivelling can only be carried out if the DSMH2-12V is hanging on a crane hook or similar, i.e. the hydraulic pump (42.1) is in the vertical position.

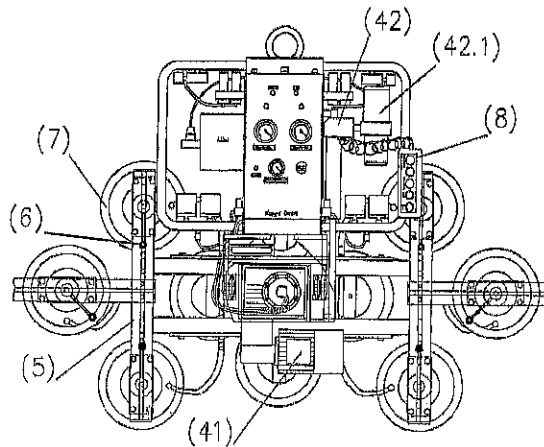

## Caution

- An uneven (A) load distribution is not permitted during rotation!
- Ensure an even (B) load distribution during rotation.
- The surface must be absolutely free of dust, rust particles, water and similar

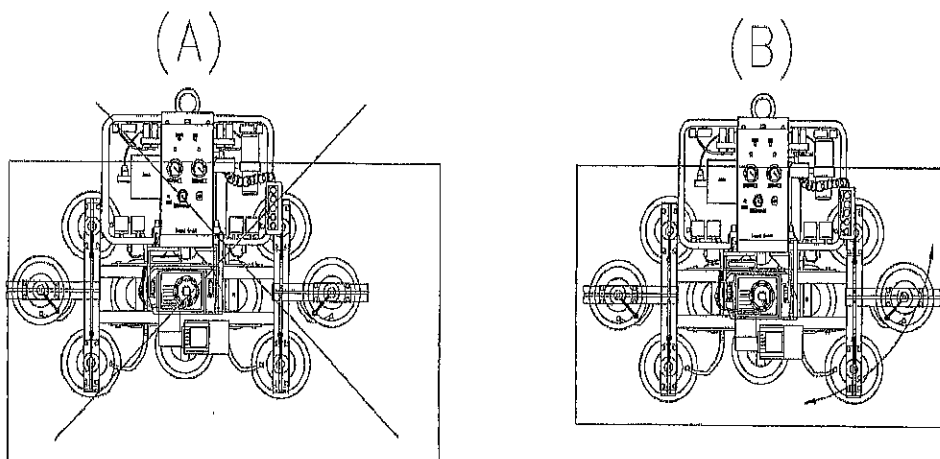

### Caution

- Top-heavy (C) load distribution is not permitted during swivelling.
- Even (D) load distribution is not permitted during swivelling.
- Ensure bottom-heavy (E) load distribution during swivelling

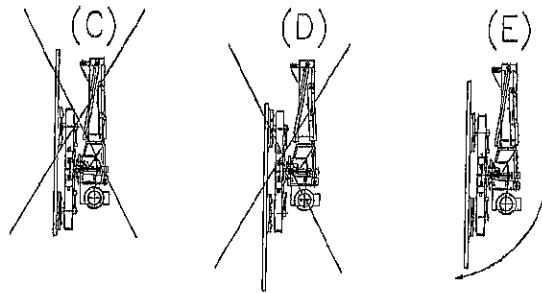

Check that all suckers on the surface are clean and have full contact and, if necessary, press on or align a sucker that is not making contact until it is in the correct position. If this is not done, a vacuum cannot build up and the DSMH2-12V can therefore not lift the material. Set the two suction/release valves (2.1 and 2.2) to SUCTION using the remote control.

### Caution

- The stop valves on the reserve tanks must be opened.

Check the vacuum achieved using the two inspection vacuum meters (3.1 and 3.2). The two vacuum indicator lights (14.1 and 14.2 red) and the signal tone (11) indicate insufficient vacuum. The transport procedure can take place with the pumps switched off as soon as there is -0.72 bar vacuum in each of the two vacuum circuits.

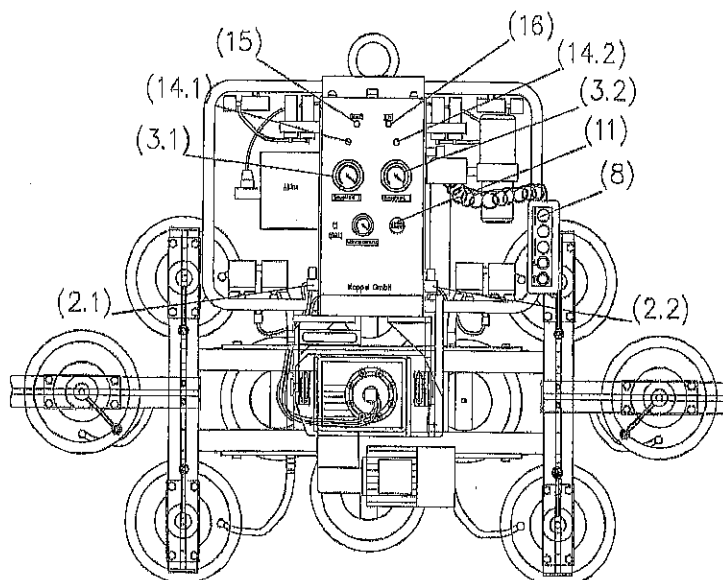

## Danger

- Do not convey loads over persons or machines.

If the vacuum sinks below -0.65 bar in both or only one of the vacuum circuits during transport work, a signal tone sounds (11). In this case, try to set down the load as soon as possible so that it does not fall down

The transported goods are guided from the side, which means that the operator stands as far as possible from the transported goods in order to guide them.

To rotate or swivel the transported goods with the remote control (8) see page 3-3, the transported goods must always be positioned according to the drawing (B) or (E). It must also be ensured that the rotation or swivelling motion can be performed without danger and that no damage occurs to the transported goods.

The transported goods are rotated and swivelled from the side, which means that the operator stands outside the area in which the transported goods are rotated or swivelled.

If you want to release the transported goods, set the two suction/release valves (2.1 and 2.2) to the RELEASE position using the remote control (8).

The vacuum decreases and the cross arm is released from the transported goods. If the two inspection vacuum meters (3.1 and 3.2) indicate 0, the procedure is completed and the cross arm is released from the transported goods. It can occur that the DSMH2-12V remains stuck to the transported goods only to then release them, which can lead to a small shock that shakes the transported goods. Therefore hold on tightly to the transported goods during the release procedure.

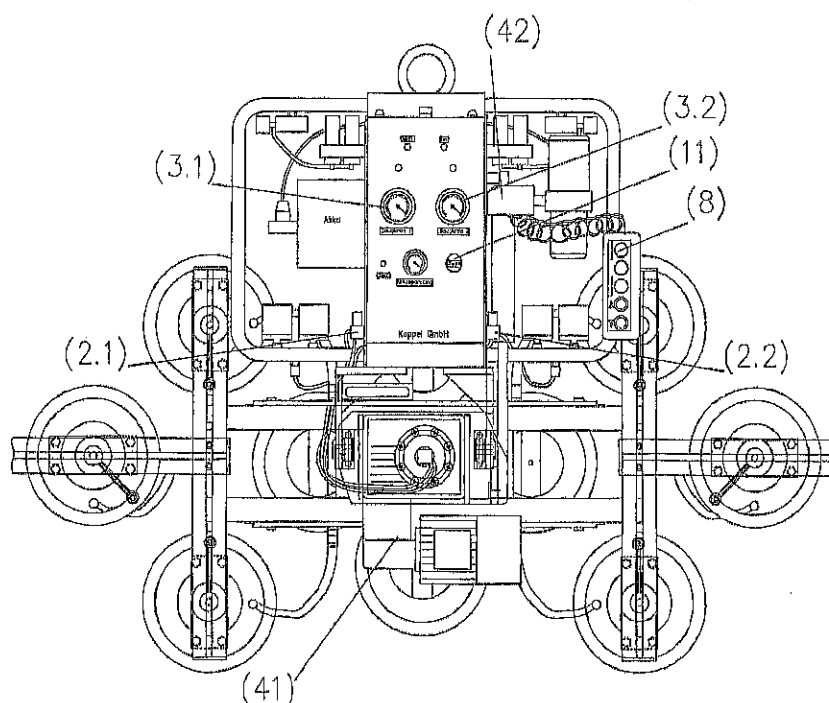

## Note

- If the batteries are drained, you can also use the DSMH2-12V in network mode. You only have to ensure that the cable to the network supply line is run appropriately.

## Switching off

After completing transport work, switch the machine off using the switch (10) in order not to drain the batteries unnecessarily.

## Charging the batteries

Check the DSMH2-12V for any externally recognisable damage or flaws.

Compare the connection on the power supply network with regard to voltage, current, and mechanical connection (plug connection) with the necessary data for the vacuum pumps. If they do not correspond, the machine may not be operated.

Connect the DSMH2-12V to the mains power supply at the plug (9) using an extension cable.

The charging procedure can be checked in voltage display (13) after the Test (12) button has been pressed.

After the charging procedure is completed, a value of 100% must be visible in the voltage display when Test button (12) is pushed.

The batteries are loaded after a maximum of 12 hours.

Remove the extension cable from the mains power supply

This completes the loading.

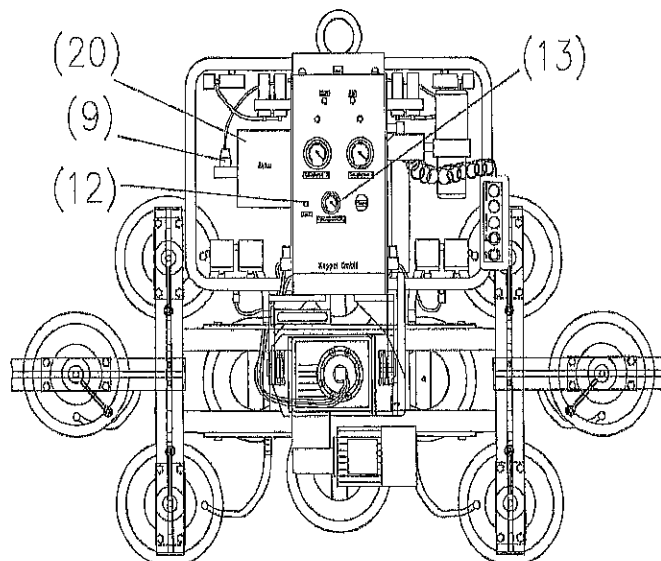

## Troubleshooting

### Pumps no longer perform correctly

The machine no longer reaches -0,72 bar vacuum.

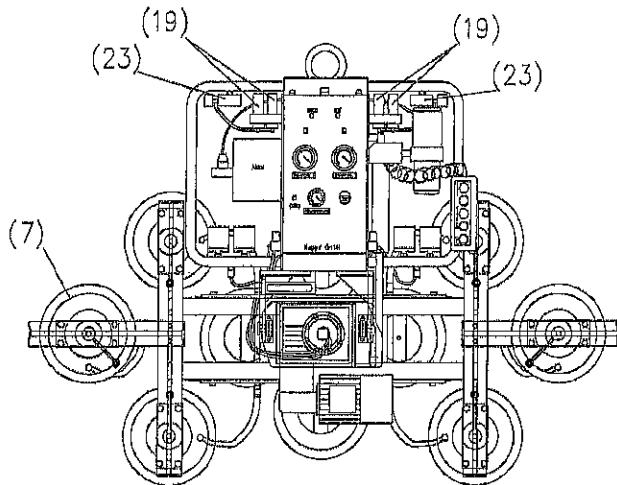

- Please check whether all suckers (7) contact the transported goods cleanly; align them if necessary.
- Check the suckers and hose lines for possible damage and replace them if necessary.

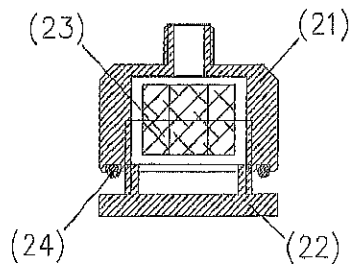

- Check the dirt filters (23) for contamination and clean them if necessary.
- (21) Filter casing
- (22) Filter cover
- (24) O-ring
- Check hose clamps for firm fit and tighten them if necessary.

## Leak check

### Leak check for the entire system

You can perform a leak check of the two independently functioning vacuum circuits to find the leak as follows.

First of all, you should check the entire vacuum circuits with all suckers (7) and the hose lines to the two vacuum circuits. To do so, the two magnetic suction/release valves (2.1 and 2.2) should be set to **SUCTION** using the remote control. Furthermore, it is necessary to set all suckers on a gas-impermeable, flat material (for example, a metal or glass sheet) that can be sucked up. Then the vacuum pump is switched on and when the maximum achievable vacuum, as a rule approx. -0.72 bar in each vacuum circuit is achieved, the pumps are switched off. Read the achieved vacuum from the vacuum meters (3.1 and 3.2) and record the value in writing. The indicators of the vacuum meters (3.1 and 3.2) are only permitted to change slightly within the next fifteen minutes, not more than 5%. If the result of this test is positive, the vacuum lifting device is tight and you can work with it without risk. If a leak is detected even in one vacuum circuit, the leak must be corrected immediately or the porous material replaced.

### Leak check without sucker

If the result of the test of the entire circuit is negative, the next step is to check the vacuum reserve tanks with the supply lines to the connections of the individual suckers (six per vacuum circuit). To do so, set the magnetic valves (2.1 and 2.2) to **SUCTION** and block the hose line to the individual suckers at the stop valves (26). Then switch the vacuum pumps on and continue with the leak test as described above. If this test runs positively, it is tight from the vessel areas to the individual stop valves (26) and the error must be in the supply lines of the individual suckers or at the suckers themselves (7). Connect one sucker (7) after the other and test each one in the same way. To do this, the sucker (7) must be sealed with a gas-impermeable material. This procedure determines the defective area exactly and the error can be corrected quickly by replacement.

### Note

- Blue hoses = vacuum circuit 1
- Black hoses = vacuum circuit 2

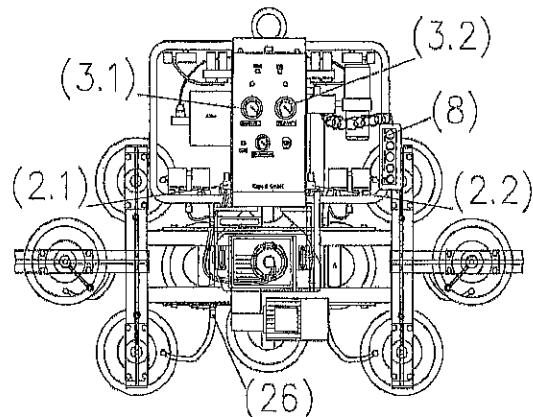

## Electrical malfunction

Vacuum pumps do not start when the device switch is actuated

- Vacuum supply sufficient. Device running correctly.
- Batteries empty? Press button Test (12) to check voltage display. Run machine in mains operation or charge batteries.
- Check safety cutout S2 (17)
- Have motor cables of pumps (19) checked by expert for possible cable break.
- Vacuum monitor for switching point P2 (28.1 or 28.2) defect? Replace.
- Circuit board defect? Have circuit board checked by an expert.
- Relay fuse in switch cabinet R7 and R8 defect? Replace.

Mains operation not possible

- Main control light (15) is not on? Check safety cutout S1 (18).
- Have mains supply checked by an expert.

Vacuum pumps do not switch off when -0.72 bar vacuum is reached.

- Vacuum monitor P2 (28.1 or 28.2) defect. Replace.
- Circuit board defect? Have circuit board checked by an expert.

No warning signals

- Vacuum above -0.65 bar? Device OK.
- Vacuum monitor P1 (27.1 or 27.2) defect? Replace.
- Signal buzzer defect (11)? Replace.

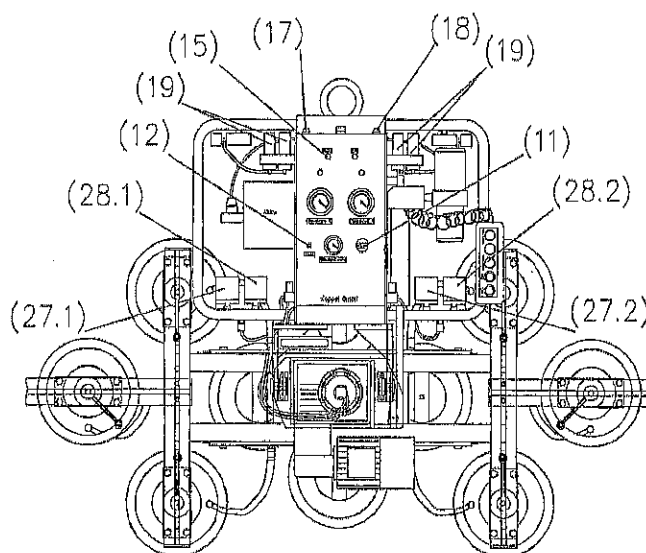



## Electrical malfunction

### Rotation cannot be carried out

- Pumps are active
- The 25A fuse in the junction plate of the geared motor is defect due to overloading

### Swivelling cannot be carried out

- Pumps are active

### The geared motor

- Maintenance-free

### The hydraulic pump with cylinder

- Maintenance-free

## Maintenance

### Note

Please note that the trades association requires an annual inspection of vacuum lifting devices by a specialist, in accordance with the accident prevent regulations (VbG 9a-prEN 13155:1998). If you do not have a suitable staff member, we offer a maintenance contract for our vacuum lifting devices which includes annual maintenance including testing and certification. Please contact us for details.

Kappel Flachglastechnik GmbH  
Schlachthofstraße 3-5  
D-87700 Memmingen  
Phone: (+49) 8331 / 4487  
Fax: (+49) 8331 / 82962

### The suckers

The suckers (7) must be cleaned occasionally with a clean cloth. Please do not use a solvent (such as gasoline or similar substances). Never treat the suckers with talc, lubricants, or smoothing agents, as this impairs the adhesion of the suckers, causing the transported goods to slip from them.

### The vacuum lines

The hoses must be inspected occasionally for visible cracks, etc. Replace defective hoses immediately!

### Note

- Blue hoses = vacuum circuit 1
- Black hoses = vacuum circuit 2

## Leak check

A leak test of the two independently functioning vacuum circuits must be performed at least once a week. First you should check the entire vacuum circuit with all suckers and the hose lines.

To do this, it is necessary to set all suckers of the vacuum cross bar on a gas-impermeable, flat material (for example, a metal or glass sheet) that can be sucked up. Also set the magnetic suction/loosening valves (2.1 and 2.2) to SUCTION using the remote control. Then the vacuum pumps are switched on, and when the maximum achievable vacuum, as a rule approx. -0.72 bar in each vacuum circuit, has been achieved, the pumps are switched off. Read the achieved vacuum from the vacuum meters (3.1 and 3.2) and record the value in writing. The indicator of the vacuum meters (3.1 and 3.2) is only permitted to change slightly within the next 15 minutes, not more than 5%. If the result of this test is positive, the vacuum lifting device is tight, and you can work with it without risk.

If the test of one of the vacuum circuits is negative, you can repair the leak and seal it or replace the leaking material, as described in the Troubleshooting chapter. The leak must be corrected immediately or the porous material replaced.

### Caution

Always check the operational safety of the pumps and the other elements before starting work / commissioning.

### Caution

The DSMH2-12V must **NEVER** be commissioned if only **one** of the vacuum circuits is functioning.

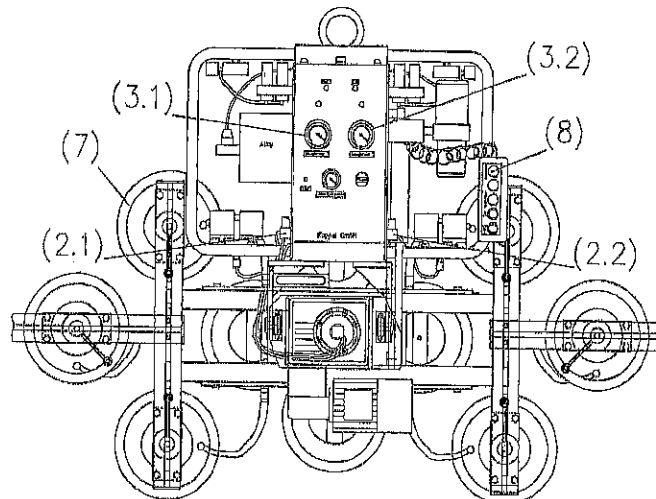

## Technical data

Manufacturer:	Kappel Flachglastechnik GmbH
Designation:	Vacuum lifting device (battery operated)
Type:	DSMH2-12V
Serial number:	<u>505</u>
Year of manufacture:	<u>2015</u>
Operating instructions:	Art. no: KA-DSMH2-12V
Manufacturer's address:	Kappel Flachglastechnik GmbH Schlachthofstraße 3-5 D-87700 Memmingen Phone: 08331/4487 Fax: 08331/82962
After-sales service:	Phone: 08331/4487

## Performance data for DSMH2-12V

### Maximum size of the plate material to be transported

Height:	approx. 2000 mm
Width:	approx. 3000 mm

### Width extensions

Height:	approx. 3210 mm
Width:	approx. 6000 mm

### Frame size

Height:	1000 mm
Width:	1230 mm
Depth:	360 mm

### Temperature range

Operating temperature	+1 to +35°C (ambient)
Storage temperature	+1 to +50°C (ambient)

### Dead weight

150 kg

### Vacuum storage tank

1<sup>st</sup> vacuum circuit 1.5 litre / 2<sup>nd</sup> circuit 1,5 litre

### Hose connection

6 mm

Any information regarding the carrying capacity refers to even surface load. Furthermore, all suckers must have solid suction contact with the goods to be transported.

DSMH2-12V, supplied with suckers type 388K

Number of suckers 12

DSMH2-12V with suckers type 388 K

Carrying capacity vertical: 600 kg with 12 suckers  
Carrying capacity horizontal: 600 kg with 12 suckers

Suckers type 388 K

Diameter:	300 mm
Carrying capacity on smooth, clean, dry Surface with 60% vacuum	
Vertical:	100 kg
Horizontal:	100 kg
Vacuum connection:	9 mm

Two vacuum pumps / vacuum circuit

Supply voltage:	12V, DC
Nominal current:	approx. 8A

One battery

Supply voltage:	12V, DC
Nominal capacity:	approx. 18 Ah

Mains operation

Supply voltage:	220-240V, AC
Mains frequency:	50/60 Hz

Rotary drive

Geared motor	12V 180W
--------------	----------

Swivel drive

Hydraulic cylinder with pump	12V 150W
------------------------------	----------

Wiring diagram DSMH2-12V

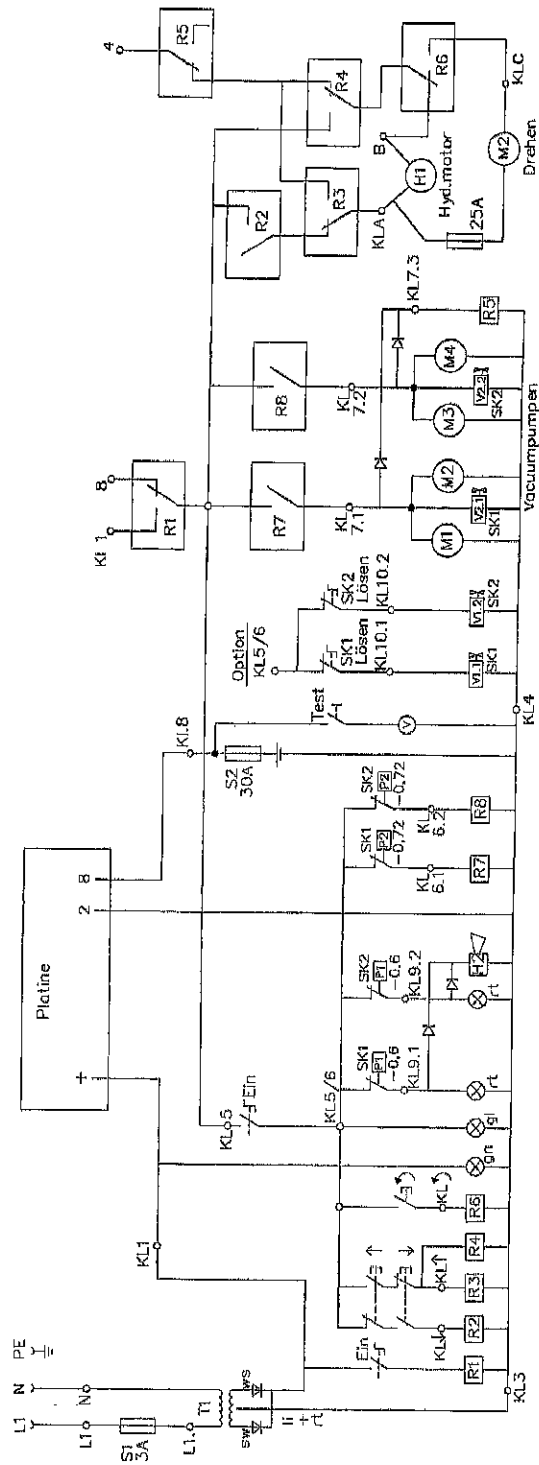

## Spare parts list for DSMH2-12V

Position	Order no.	Quantity	Designation
1	M16 / 1,2t, 135597	1	Suspension eye/articulated suspension
2.1 and 2.2 valve	P10.00410-12DC	2	3/2 way magnetic valve 1/4", suction/release
3.1 and 3.2	LX98206	2	Vacuum meter 12V 63mm 1/4"
4	-----	1	Basic frame
5	-----	1	Carrier frame
6	63.902.121	6	Clamping lever, internal thread
7	388K	12	Suction pad 388 Kappel
8	-----	4	Remote control
9	905708	1	Scuco plug
10	723999	1	Selector switch, locking ZA2BD2 telem.
11	118.068.14	1	Buzzer (horn) 12V DC
12	706124	1	Test button, push-button, red
13	64590	1	Charge indicator 12 V DC
14.1 and 14.2	726052	2	LED indicator lamp 12V, red (alarm)
15	726079	1	LED indicator lamp 12V ultra green (network)
16	726060	1	LED indicator lamp 12V, yellow (pump)
17	106-P10-30 Amp.	2	ETA circuit breaker 30 amp.(S2)
18	106-P10-3 Amp.	1	ETA circuit breaker 3 amp.(S1)
19	0826-02	4	DC 12/90S
20	-----	1	Battery 12V DC 18Ah
21	FG99001	2	Filter casing for air filter (aluminum)
22	FG99002	2	Cover for filter casing, air filter (aluminum)
23	EIT-175-SL 8369	2	Filter element for air filter (aluminum)
24	O-Ring 37x3	2	O ring 37x3 for air filter (aluminum)
25	FLUID	2	3/2 way valve 1/8" 12V
26	MWL008,0035	12	Mini ball valve 1/4" la /stop valve
27.1 and 27.2	6.256.540	2	Vacuum control, type 625 (P1)
28.1 and 28.2	6.256.540	2	Vacuum control, type 625 (P2)
29	105134	4	Cover, red, for vacuum control
30	-----	-----	Optional for remote control
31	-----	1	Clamp for batteries
32	HR5LA42.OPP	2	High-pressure pipe clamps Gr.5 D42 cpl. for vacuum pumps DC 12/90S
33	LX98237	2	Front ring for vacuum meters 63 mm
34	43	12	U-washer for clamping lever Washer D 78 / d 12x4
35	Distributor tube rail	2	Distributor tube rail, paired
36	Rectus 18	2	1/4" vacuum S.S. couplings for extensions
37	X20128501	1	Protection cap for ETA series 106
38	X21066301	1	Protection cap for ETA series 3400,5700 IG2
39	501140	1	Bridge rectifier B80 25A silicium
40	859829	1	Magn. core transf. RKT 200VA / 230V / 2x12V
41	-----	1	Rotary device
42	-----	1	Swivelling device
43	736806	1	Flange ZA2BZ009
44	734310	1	Auxiliary switch ZB2BE101 close contact
45	527939	2	Guide strip O
46	452373	10	WAG lead-through terminal 280-641 grey
47	452372	2	WAG lead-through terminal 280-637 gr/ye SL terminal
48	452375	1	WAG lead-through terminal 280-651 bl
49	361999	2	WAG lead-through terminal 280-654 or



- \* Zweikreisystem Vakuumsauggeräte
- \* Sauggeräte für innerbetriebliche Fertigungen
- \* Sonderanfertigungen für Glashandlung
- \* Service

Robert Kappel GmbH - Schlachthofstr.3-5 - D-87700 Memmingen

Sales, technical after-sale service,  
repairs on tools, machines and equipment  
for flat glass processing as well as  
hydraulic / pneumatic  
equipment and devices

Robert  
KAPPEL  
GmbH  
87700 Memmingen

Tel. (0 83 31) 44 87  
Fax (0 83 31) 8 29 62

### Inspection Certificate for vacuum pumps

Customer <i>Wienhold Embüren</i>		Maintenance contract no. <i>UK</i>	
Year of manufacture <i>2005</i>		Type of hanger <i>DS/H2-12V</i>	
Type of pump / inflow / take nozzle <i>Dynaflo 2+</i>		Number of suckers <i>16 x ASOL</i>	
		No. <i>505</i>	
		Year of manufacture <i>2005</i>	
OPTICAL CHECK			
	Good condition	Has been renewed	Must be renewed
Suction pads	<input checked="" type="checkbox"/>	<input checked="" type="checkbox"/>	
Hanger hoses	<input checked="" type="checkbox"/>		
Vacuum tank	<input checked="" type="checkbox"/>		
Hose recoilers			
Clamps	<input checked="" type="checkbox"/>		
FUNCTIONAL TEST			
		OK	
Vacuum capacity / inflow / take nozzle / pump	yes	<input checked="" type="checkbox"/>	no
Installation position hose recoiler	yes	<input checked="" type="checkbox"/>	no
Switching function vacuum control <i>0,6 bar</i>	yes	<input checked="" type="checkbox"/>	no
Hand valve functioning (incl. SS coupling)	yes	<input checked="" type="checkbox"/>	no
Establishing of vacuum (at least 0.65 bar) <i>0,72 bar</i>	yes	<input checked="" type="checkbox"/>	no
Leak tightness (vacuum equipment)	yes	<input checked="" type="checkbox"/>	no
Leak tightness (vacuum tank)	yes	<input checked="" type="checkbox"/>	no
ACCEPTANCE TEST			
Equipment has been accepted correctly	yes	<input checked="" type="checkbox"/>	no
Re-examination necessary after remedy of defects	yes		<input checked="" type="checkbox"/>
Equipment is ready for operation	yes	<input checked="" type="checkbox"/>	no
Remarks: <i>New</i>			

Scope of test fulfilled in accordance with BGR 500  
Kap. 2,8 by specialist

Next acceptance test *01* month *2006* year  
*Memmingen* Place *27.1.06* Date

Robert Kappel GmbH  
Memmingen

*Kappel*  
Signature

## CE Declaration of conformity

in terms of the CE directive

Document no.: 00012/03.98

Product name: DS Kombi, 12V  
with accessories

Serial number: 505

Manufacturer: Robert Kappel GmbH  
Schlachthofstr. 3/5  
87700 Memmingen

Conformance of the product with the Directives No. 89/336 73/73 is given according to the following standards:

### Harmonized European standards:

EN 13155 Non fixed load lifting attachments  
DIN EN 292 Part 1 Safety of machinery  
DIN EN 60 204 Part 1 Safety of machinery - Electrical equipment of machines

VDE 0100 Part 530 Selection and erection of electrical equipment -  
Switchgear and controlgear

### The following standard, directives and specifications are applied:

BGR 500 Kap. 2.8 Load Suspension Gear on Crane Equipment

A complete technical documentation is available.  
Operating instructions for the unit are available.

27.1.05  
Memmingen,

[Signature]  
Roland Kappel, Managing director



# Daily Pre-Use Checklist

## Vacuum Lifter

Northern (Head Office) Tel: +44 (0)1482 227333

Central Tel: +44 (0)1302 341659

Western Tel: +44 (0)1384 900388

Southern Tel: +44 (0)203 174 0658

www.hird.co.uk

Machine Model: <b>Kappel Hydraulica 1000</b>		Site Name:
Date Week Commencing:	Fleet No:	Address:
Inspected by:		

Daily Pre-use Checks		M	T	W	T	F	S	S	COMMENTS
1	Are all operators manuals present and readable								
2	Is the Report of Thorough Examination (LOLER) in date								
3	Complete a visual walk around / Inspection for any noticeable defects								
4	Are all safety information decals present and readable								

**Check the following components or areas for damage, or missing parts & unauthorised modifications:**

5	Is the lifting attachment free from defects and safe to use								
6	Vacuum pads for rips, tears, quality and cleanliness								
7	Vacuum pipes and connections (in particular quick release fittings)								
8	All extension arms are present and free from defects (where applicable)								
9	Make sure all individual pad shut off valves are open (where applicable)								
10	Electrical components, wiring, connectors,								
11	Check input mains voltage corresponds with charger voltage (110v or 240v)								
12	Charger								
13	Check battery has sufficient charge								
14	Are rotation and tilting movements functional								
15	Check handles security								
16	Check remote for any damage or defects (where applicable)								
17	Check operation buttons / switches are working and free from defects								
18	Energise vacuum on non porous surface								
19	Are lights and audible alarms on during vacuum process								
20	Does the vacuum reach sufficient level, before switching off (see gauges)								
21	Does battery gauge illuminate when pump switches off <b>If NO - DO NOT USE</b>								
22	Check Safe Working load of vacuum - is it suitable for the proposed load								
23	Carry out full function test								

Is the machine safe to use? (please circle)	YES	YES	YES	YES	YES	YES	YES
	NO	NO	NO	NO	NO	NO	NO

Operator's Initials							
---------------------	--	--	--	--	--	--	--

Result of Inspections: List defects or state "No Defects"
---

Signature:	Name:	Date:
------------	-------	-------