

HIRD
GLASS

www.hird.co.uk

OPERATOR MANUAL

KAPPEL DSZ2 - 900KG

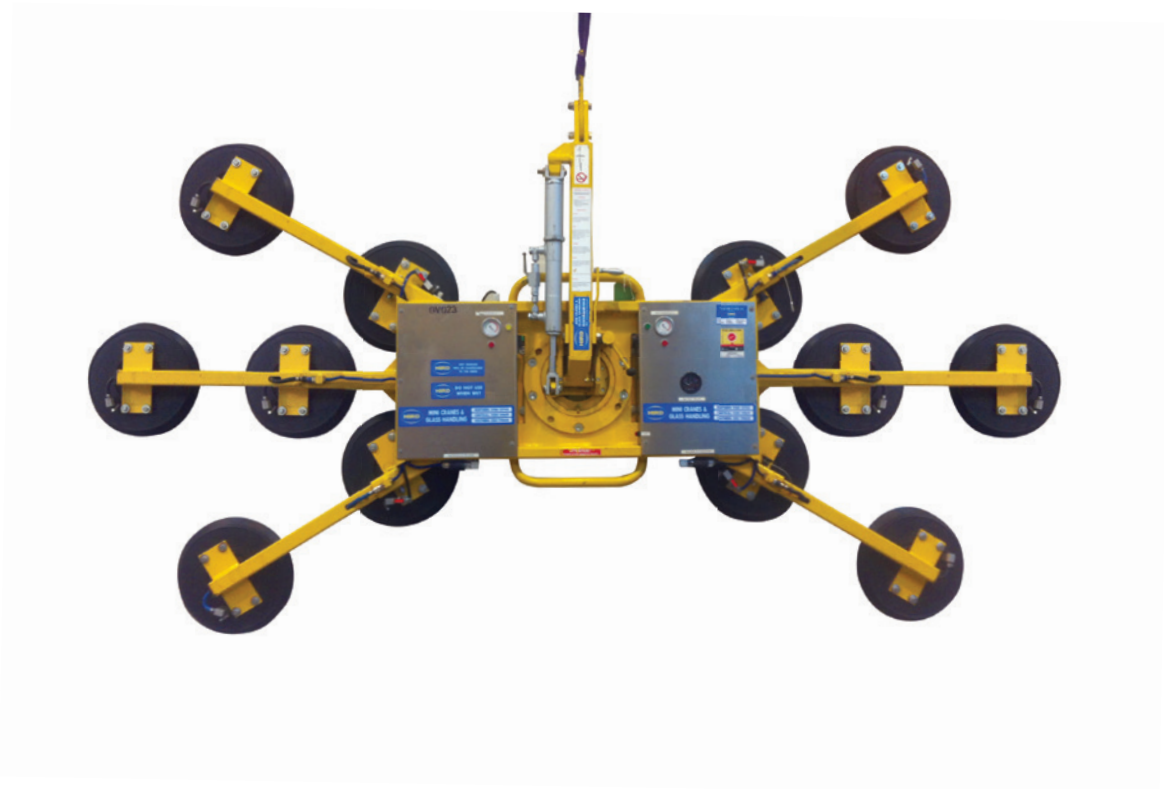

Northern (Head Office)
Tel: +44 (0)1482 227333

Central
Tel: +44 (0)1302 341659

Western
Tel: +44 (0)1384 900388

Southern
Tel: +44 (0)203 174 0658

Table of contents

Preface	1-1
Technical description	1-2
Basic safety information	2-1
Warning instructions and symbols	2-1
Authorized use	2-1
Organizational measures	2-2
Personal selection and qualification	2-3
Safety instructions on particular operating phases	2-3
Normal operation	2-3
Special work	2-4
Safety instructions for special danger types	2-4
Electrical power	2-4
Oils, greases, and other chemical substances	2-4
Commissioning	3-1
Charging the batteries	3-2
Remote control	3-3
Before transporting	3-4
Operation	4-1
Switching on	4-2
Working cycle	4-3
Switching off	4-6
Charging the batteries	4-6

Trouble shooting	5-1
Pumps no longer perform correctly	5-1
Leak check	5-2
Leak check for the entire system	5-2
Leak check without suction cups	5-2
Electrical malfunction	5-3
Vacuum pump does not start when the device switch is actuated	5-3
Vacuum pump does not switch on when vacuum of -0.72 bar is reached	5-3
No warning signal	5-3
Maintenance	6-1
The suction cups	6-1
The vacuum lines	6-1
Leak check	6-2
The vacuum pump	See appendix
Technical data	7-1
Performance data for the DSZ2-12V	7-2
Options for the DSZ2-12V /	7-3
Circuit diagram DSZ2-12V	7-4
Spare parts list	8-1
Test report for suction cup 150/K	See appendix

Preface

These operating instructions are intended to help you become familiar with the DSZ2-12V and to use it as intended.

These operating instructions contain important instructions on operating the DSZ2-12V safely, effectively, and economically. Observing them helps to avoid repair costs and down time and to increase the reliability and working life of the DSZ2-12V.

These operating instructions must be supplemented by additional instructions due to existing national accident prevention regulations.

These operating instructions must always be available at the site of use of the DSZ2-12V.

These operating instructions must be read and observed by every person responsible for doing work on the DSZ2-12V, for example:

- operation, including equipping, trouble shooting during operation, removal of production wastes, care
- maintenance (servicing, inspection, repair) and/or
- transport.

In addition to the operating instructions and binding accident prevention regulations applicable for the country of use and the application case, the recognized technical rules for safe and professional work must also be observed.

If you discover errors when reading these operating instructions, or if you have further comments or suggestions, please contact:

Kappel Flachglastechnik GmbH
Schlachthofstraße 3-5
87700 Memmingen

The management appreciates your cooperation.

Technical description

The DSZ2-12V is a combination of two vacuum pumps with power supply (battery including charger) and a vacuum cross arm with two independently working vacuum circuits. This vacuum cross arm with two-row suction cup arrangement is intended for flexible use on construction sites, at various crane systems, etc., anywhere where a 220 to 240 volt connection is available. Using the DSZ2-12V, the transfer material can be rotated by 360 degrees and also be swivelled by 90 degrees.

The DSZ2-12V is hung on a crane hook and is supplied with energy via installed batteries. In addition to easy installation on a crane or similar device, the DSZ2-12V also offers the safety advantage that in general no vacuum supply hose or voltage supply line is required as is the case with separated devices (cross arm, vacuum pump). In addition, it is also possible to lower the transfer material during a power outage with this type of device as long as the two vacuum circuits are perfectly sealed, because the vacuum reserve tank is located on the vacuum cross arm.

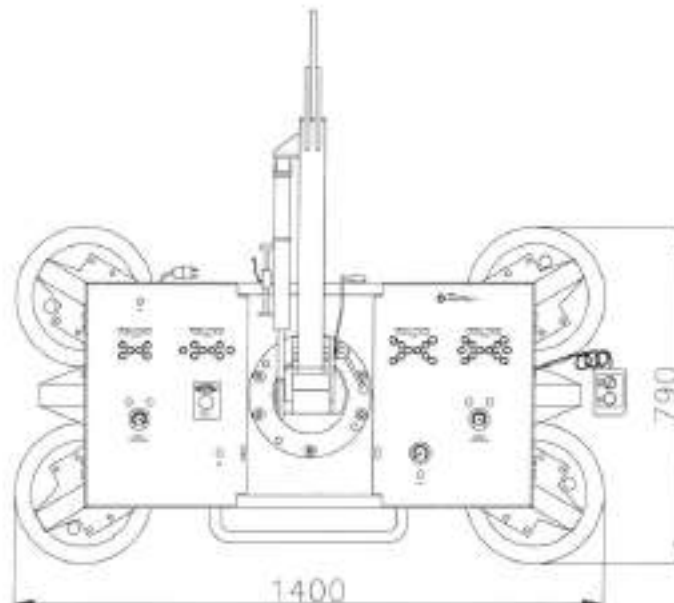

In particular, the device consists of a rectangular tube frame with suspension eye, the basic frame. A second rectangular tube frame is connected to this basic frame first via a swivelling joint and then via a rotating joint. This frame is the carrier frame which simultaneously forms the vacuum reserve tank and holds the vacuum pump, the battery loading device, and the batteries.

The suction cups are also mounted to this carrier frame. Switchover between SUCTION and LOOSEN can also be controlled via remote control. The suction cups (three suction cups per vacuum circuit) can be blocked individually using vacuum couplings. The two inspection vacuum gauges provide information on the exact pressure ratios in the vacuum lines to the individual suction cups. A voltage display indicates the battery charge level.

The charging circuit voltage for the charger is 220-240 Volt AC (50/60 Hz).

Two vacuum pumps are used to generate the vacuum (one vacuum pump per vacuum circuit). The vacuum pumps work without oil lubrication and are therefore maintenance-free.

In order to avoid draining the batteries unnecessarily, the pump switch has a two-point controller that switches off the vacuum when the pressure reaches -0.72 bar in the vessel and switches it back on when the pressure falls below approx. -0.68. This avoids premature draining of the batteries by letting the pump run unnecessarily. The batteries are maintenance-free and enclosed. They are total discharge-safe.

Mode of operation

Switch the machine on using the ON/OFF switch. Turn the suction switch to OFF. The vacuum cross arm must be positioned on the load to be transported in such a way that all suction cups are flat on the smooth clean surface so that the suction cup lips can seal completely. Turn the suction switch to ON and wait until the pumps in both vacuum circuits are switched off. You can check the vacuum using the vacuum gauges 1 and 2 on the device. If a vacuum of -0.72 bar is present in each of the vacuum circuits, the load can be transported. To loosen the suction cups from the load, turn the suction switch to OFF and press the loosen key.

Caution

NEVER operate the DSY2-12V **with only one** operative vacuum circuit.

Basic safety instructions

Warning instructions and symbols

The following terms and symbols are used in the operator's manual for especially important information:

Note Special information regarding the economical use of the device

Caution Special information regarding requirements and prohibitions to prevent damage.

Danger Information or requirements or prohibitions to protect people or prevent extensive damage.

Authorized use

The DSZ2-12V has been constructed in accordance with the state of the art and recognized safety regulations. Nevertheless, its use may result in danger to life and limb of the operator or third parties, and impairment of the machine or other property may occur.

The machine may only be used when in technically perfect condition, as authorized, with consciousness of safety and risks, and in compliance with these operating instructions! Failures that can interfere with safety must be eliminated immediately!

The DSZ2-12V is exclusively designed for transporting gas-tight, dry materials with firm, flat surfaces. Other use or use going beyond this, for example transporting gas-permeable materials, film-covered materials, wet materials, or rotating or swivelling large or heavy transfer items is not authorized. The manufacturer/supplier is not liable for the damages resulting from this. The user carries the risk.

Use as authorized also includes compliance with the operating instructions and the inspection and maintenance conditions.

Organizational measures

Always keep the operating instructions within reach at the site where the machine is used!

In addition to the operating instructions, observe and teach the generally applicable legal and other binding accident prevention regulations!

Such obligations can also include providing and wearing personal protective equipment.

Supplement the operating instructions with instructions including supervision and reporting obligations taking into consideration special circumstances at the company with regard to work organization, work processes, and personnel used.

The personnel charged with working on the machine must have read the operating instructions, in particular the chapter on safety instructions, before starting work. If you have already started work, it is already too late. This applies in particular to personnel that work on the machine only occasionally, for example during equipping and maintenance.

Check at least occasionally to ensure safe and risk-conscious work in compliance with the operating instructions from the personnel!

If necessary or required by regulations, use personal protective equipment! Transport glass only with appropriate protective equipment (safety shoes, protective gloves, wrist protectors, helmets, etc.). Always wear a helmet when transporting items above head height.

Comply with all safety and danger instructions on the device!

Keep all safety and danger signs on the equipment in legible condition!

If safety-related changes to the machine or its operations occur, stop the machine immediately and report the malfunction to the responsible office or person!

No changes or attachments or detachments to the machine that could impair safety may be performed without the written consent of the supplier! This applies to the installation and setting of safety equipment of all types as well as to welding on carrying parts.

Replacement parts must meet the technical requirements specified by the manufacturer. This is always guaranteed with original replacement parts.

Replace vacuum hose lines at the intervals given in the maintenance plan, even if there are no recognizable safety defects!

Comply with mandated deadlines for recurring tests/inspections and with those specified in the operating instructions!

Performing the maintenance measures absolutely requires workshop equipment that meets the requirements.

Personal selection and qualification

Work on/with the machine may only be performed by reliable personnel. Observe the legal minimum working age!

Use only trained or instructed personnel; competencies among personnel shall be clearly established for operation, equipping, maintenance, and repair!

Ensure that only authorized personnel works on the machine!

Specify a person as being responsible for operating the machine and allow him to refuse to comply with the safety-relevant instructions of third parties!

Personnel being trained or instructed, or personnel taking part in a general training program, may only work on the machine when under constant supervision of a person experienced and familiar with the machine!

Any work on the electrical equipment of the machine must only be performed by an electrician or by trained personnel under the direction and supervision of an electrician in accordance with the rules of electrical engineering.

Safety instructions on particular operating phases

Normal operation

Avoid all unsafe work practices!

Before starting work, become familiar with the working environment at the site of use. The working environment includes impediments in the work and traffic area, the load carrying capacity of the floor, and cordoning off the worksite from the public traffic areas.

Take measures to ensure that the machine is only operated when safe and functional!

Check the machine for externally recognizable damages and flaws at least once per shift! Report any changes that occur (including those to the operating behaviour) immediately to the responsible office/person! If necessary, stop the machine immediately and secure it!

During malfunctions, stop the machine immediately and secure it! Correct malfunctions immediately!

Comply with switching on and off procedures, and monitor the inspection displays according to the operating instructions!

Always stop work if it becomes dark or if visibility is poor!

Special work

The setting, maintenance, and inspection activities and deadlines, including information on replacement of parts and modules must be observed! These activities must only be performed by authorized specialists.

Only perform maintenance and repair work when the machine is positioned on flat ground with sufficient carrying capacity and is secured against rolling away or collapsing!

Clean machines, particularly connections and screw connections at the beginning of maintenance/repair! Do not use aggressive cleaning agents! Use lint-free cloths for cleaning!

Never clean the machine with water or steam jet (high-pressure cleaner).

After cleaning, inspect all vacuum lines for leaks, loosened connections, abrasions, and damages! Repair any flaws immediately!

Always tighten screw connections loosened during maintenance and repair work!

Safety instructions for special danger types

Electrical power

Use only original fuses with the specified current strengths! Switch off the machine immediately during malfunctions to the electrical energy supply!

Work on electrical equipment or operating materials must only be performed by an electrician or by trained personnel under the direction and supervision of an electrician in accordance with the rules and regulations of electrical engineering.

Machine and system parts on which inspection, maintenance, or repair work must be performed, must be switched free of current, if required. First check the switched off parts to ensure that they are free of voltage, then ground and short-circuit them, and insulate neighbouring parts that are under voltage!

The electrical equipment of the machine must be checked regularly. Flaws such as loose connections and melted cables must be repaired immediately.

Oils, greases, and other chemical substances

Observe the safety regulations applicable for the product when using oils, greases, and other chemical substances!

Commissioning

Note

- Do not store the DSZ2-12V in a damp or very cold (frosty) environment, otherwise it cannot be ensured that the pump will function correctly.

Caution

- Always ensure that the suction cups are not placed on sharp edges, because this could damage the suction cup lips. This would lead to leaks in the suction circuit, impairing the functioning of the device.
- Never place the machine with mounted suction cups with the rubber surfaces of the suction cups on sandy or similar ground. This could damage the sealing lips of the suction cups. This would lead to leaks in the suction circuit, impairing the functioning of the device. Or else the grains of sand and similar substances could be pressed into the rubber surfaces, leading to damages to the upper surface of the transfer material .

Danger

- Do not expose the DSZ2-12V to heavy precipitation.
- Do not place the DSZ2-12V into water.
- Do not convey loads over persons or machines. Block off the area under hanging transfer material with wide clearance.

Charging the battery

Check the DSZ2-12V for any externally recognizable damages, defects or flaws.

Compare the connection on the power supply network with regard to voltage, current, and mechanical connection (plug connection) with the necessary data for the vacuum pump. If they do not correspond, the machine must not be operated.

Connect the DSZ2-12V to the supply network at the plug using an extension cable.

You can check the charging procedure in the voltage display after pressing the "Test" button.

After the loading procedure is completed,
After pressing the Test button, the display must show 13V - 14V..

The battery is loaded after a maximum of 12 hours.

Separate the extension cable from the supply network.

This completes the loading procedure.

Note

After completing transport work, switch the machine off using switch to avoid any unnecessary discharging of the battery.

If the battery is discharged you may also operate the DSZ2-12V in mains operation.

Remote control

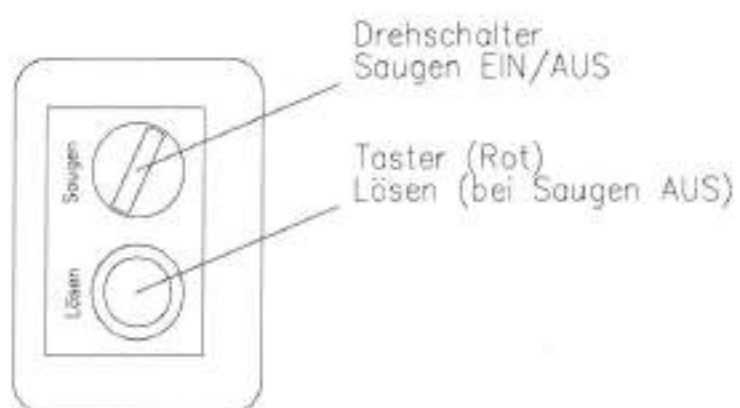

Before transporting

Check the DSZ2-12V for any externally recognizable damages, defects or flaws. Hang the DSZ2-12V from the suspension eye on a crane hook or similar device. Turn the suction switch to OFF.

Switch the machine to ON using the ON/OFF switch. The pump must start up if the vacuum is insufficient. The indicator light ON indicates that the pumps are active. If this is not the case, it is not permitted to work with the DSZ2-12V (see Trouble shooting).

The two **vacuum** indicator lamps indicate that there is insufficient vacuum in the supply lines to the suction cups. These signals depend on the vacuum in the reserve tanks. The existing vacuum in the suction frame of the two vacuum circuits can be checked on the two vacuum gauges.

After a short time, a vacuum of at least -0.65 bar should build up in each tank. The vacuum pumps switch off when -0.72 bar is reached. This should be the case after a short time.

To control the vacuum, turn the suction switch to ON and disconnect the single suction cups from the vacuum storage tanks using the vacuum couplings. The indicators of the inspection vacuum gauges must then be in the green area. Then switch the device switch off and wait for ten minutes. During this time, the indicators of the two inspection vacuum gauges are not permitted to move.

If any of the indicators changes, the DSZ2-12V is leaking and may no longer be used until the error is corrected. If this, however, is the case, the DSZ2-12V is ready to operate after switching on the main switch on the unit.

Connect the single suction cups to the vacuum storage tanks using the vacuum couplings.

In order to check the tightness of the hose lines and the individual suction cups, either a larger plate or several smaller plates of a gas-impermeable material must be present. These plates are held on the individual suction cups and then sucked on. Turn the suction switch to OFF. A vacuum of at least -0.65 bar should build up immediately in each vacuum circuit. If this happens, the machine switch must be switched off. Read the achieved vacuum from the inspection vacuum gauges and compare it with a reading taken 15 minutes later at the inspection vacuum gauges. If no deviation occurs, the device is leak-tight and safe to operate. If a deviation of more than 5% occurs,

the DSZ2-12V must be checked to find the leak (see Trouble shooting).

Commissioning is complete after you switch the machine switch back on.

Caution

NEVER operate the DSZ2-12V **with only one** operative vacuum circuit.

Operation

Note

- Do not store the DSZ2-12V in a damp or very cold (frosty) environment, otherwise it cannot be ensured that the pump will function correctly.

Switching between suction and loosen using the remote control is only possible, if the manual valve (Suction/Loosen valve) is set to "Suction".

Caution

- Always ensure that the suction cups are not placed on sharp edges, because this could damage the suction cup lips. This would lead to leaks in the suction circuit, impairing the functioning of the device.
- Never place the machine with mounted suction cups with the rubber surfaces of the suction cups on sandy or similar ground. This could damage the sealing lips of the suction cups. This would lead to leaks in the suction circuit, impairing the functioning of the device. Or else the grains of sand and similar substances could be pressed into the rubber surfaces, leading to damages to the upper surface of the transfer material .

Danger

- Do not expose the DSZ2-12V to heavy precipitation.
- Do not place the DSZ2-12V into water.
- Do not convey loads over persons or machines. Block off the area under hanging transfer material with wide clearance.

Switching on

Turn the suction switch to OFF.

Switch on the unit. The pump must start up if the vacuum is insufficient. The indicator light ON (yellow) indicates that the pumps are active. If this not the case the DSZ2-12V must not be operated (see Trouble shooting). The two 'Vacuum' indicator lamps and the alarm signal indicate insufficient vacuum. These signals depend on the vacuum in the reserve tanks.

If the DSZ2-12V is operated in mains operation this is signalled by the 'Mains' indicator lamp (green).

After a short period of time, a vacuum of at least -0.65 bar should have built up, the two vacuum indicator lamps light up, and the signal tone goes out. The vacuum pump switches off when -0.72 bar is reached. This should be the case after a short time.

As long as not transport material is used the obtained vacuum can be checked using the two control vacuum meters.

Working cycle

Determine the position of the carrier frame using the rotating or swiveling device.

Position the DSZ2-12V to the relevant transfer items.

Caution

- An uneven (A) load distribution is not permitted during rotation!
- Ensure an even (B) load distribution during rotation.
- The surface must be absolutely free of dust, rust particles, water and similar substances.

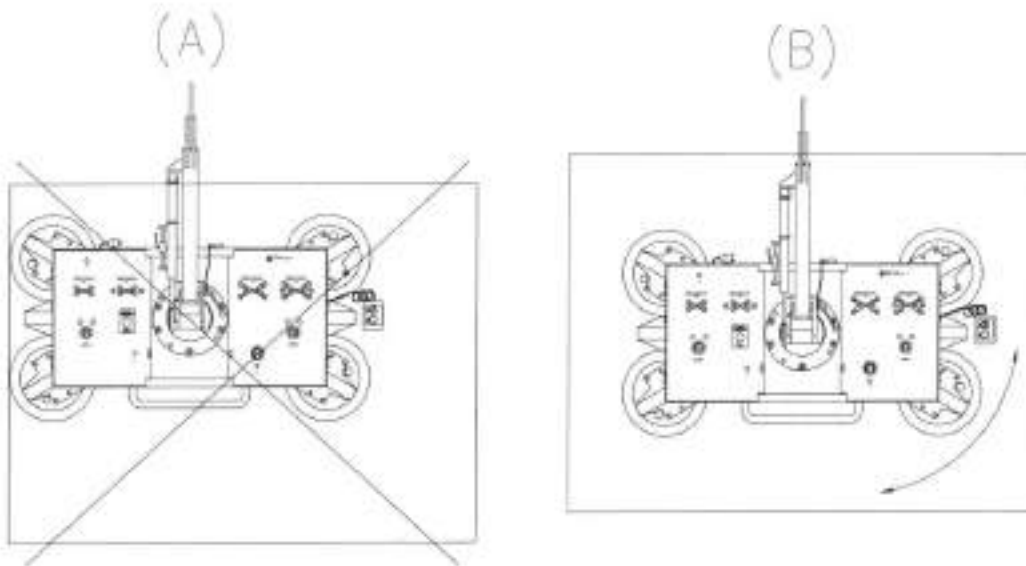

Caution

- A top-heavy (C) load distribution is not permitted during swivelling!
- An even (D) load distribution is not permitted during swivelling!
- Ensure a bottom-heavy (E) load distribution during swivelling.

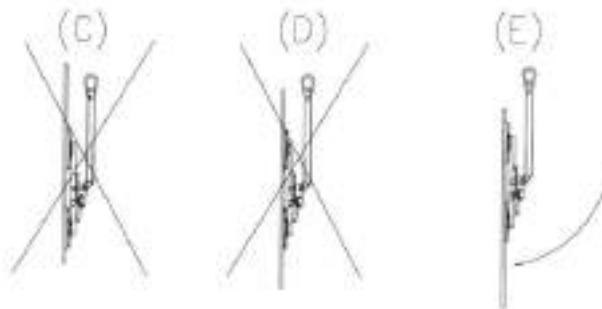

Check whether all suction cups on the surface are clean and have full contact, and if necessary press on or align a suction cup that is not making contact until it is in the correct position. If this is not done, no vacuum can build up and the DSZ2-12V cannot carry out any lifting of materials.

Turn the suction switch to ON.

Check the obtained vacuum using the two control vacuum meters.

The vacuum indicator lamps (red) and the alarm signal indicate insufficient vacuum.

Transport is possible from a vacuum of -0.72 bar in the vacuum circuit; if the pumps are switched off, i.e., the vacuum control lamps (green) light up, and the signal tone is off.

Danger

- Do not convey loads over persons or machines.
- If the vacuum sinks below -0.65 bar in both or one of the vacuum circuits during transport, a signal tone sounds. In this case, try to set down the load as soon as possible so that it does not fall down.

The transfer material is guided from the side, which means that the operator stands as far as possible from the transfer material when guiding them.

To rotate or swivel the transfer material, use the appropriate locking mechanism. The transfer material must always be positioned according to the drawing (B) or (E). It must also be ensured that the rotation or swivelling motion can be performed without danger and that no damage occurs to the transfer material. For larger plate materials, the transfer material must also be supported or held.

If the transport material needs to be removed, turn the suction switch to OFF and press the release button.

The vacuum decreases and the cross arm is released from the transfer material. If the two inspection vacuum meters indicate 0, the procedure is completed, and the traverse is released from the transfer material. It can occur that the DSZ2-12V remains stuck to the transfer material only to then release them, which can lead to a small shock that shakes the transfer material. Therefore hold the transfer material during the release procedure.

Note

- If the battery is discharged you may also operate the DSZ2-12V in mains operation. All you have to do is provide cables to the mains supply.

Switching off

After completing transport work, switch the machine off using switch to avoid any unnecessary discharging of the battery.

Charging the battery

Check the DSZ2-12V for any externally recognizable damages, defects or flaws.

Compare the connection on the power supply network with regard to voltage, current, and mechanical connection (plug connection) with the necessary data for the vacuum pump. If they do not correspond, the machine must not be operated.

Connect the DSZ2-12V to the supply network at the plug using an extension cable.

You can check the charging procedure in the voltage display after pressing the "Test" button.

After the loading procedure is completed,
After pressing the Test button, the display must show 13V - 14V..

The battery is loaded after a maximum of 12 hours.

Separate the extension cable from the supply network.

This completes the loading procedure.

Trouble shooting

Pumps no longer perform correctly

The machine no longer reaches -0.75 bar.

Please check whether all suction cups contact the transfer material correctly; align them if necessary.

Check the suction cups and hose lines for possible damages, and replace them if necessary.

Leak check

Leak check for the entire system

You can perform a leak check for both of the independently operating vacuum circuits to find the leak as follows.

First you should check the entire vacuum circuit with all suction cups and the hose lines on the two vacuum circuits. To do this, turn the switch to ON. It is also necessary to set all suction cups on a gas-impermeable, flat material (for example, a metal or glass sheet) that can be sucked up. Then switch on the OFF/ON switch. Once the maximum vacuum is reached (normally -0,72 bar in any vacuum circuit), turn the OFF/ON switch to OFF. Read the achieved vacuum from the vacuum gauges and record the value in writing. The indicators of the vacuum gauges are only permitted to change slightly in the next 15 minutes, not more than 5%. If the result of this test is positive, the vacuum lifting device is tight, and you can work with it without risk. If a leak is detected, the leak must be corrected immediately or the porous material replaced.

Leak check without suction cup

If the result of the test of the entire vacuum circuit is negative, the next step is to check the vacuum reserve tank with the supply line to the connections of the individual suction cups (three per vacuum circuit). To do this, turn the suction switch to ON; the individual suction cups are disconnected from the vacuum tanks via the vacuum couplings.

Then, turn the OFF/ON switch to ON, and continue with the leak test as described above. If this test runs positively, it is tight from the vessel to the individual vacuum couplings, and the error must be in the suction cups themselves. Connect one suction cup after the other, and test each in the same way. To do this, the suction cup must be sealed with a gas-impermeable material. This procedure determines the defective area exactly, and the error can be corrected quickly by replacement.

Note

- Blue hose connections = vacuum circuit 1
- Black hose connections = vacuum circuit 2

Electrical malfunction

Vacuum pumps do not start when the device switch is actuated

- Vacuum supply sufficient. Device running correctly.
- Batteries empty? Press button Test to check voltage display. Operate the device in mains operation, or charge batteries.
- Check fuse
Defective vacuummcontrol. Replace.

Vacuum pumps do not switch on when vacuum of -0.72 bar is reached

- Defective vacuummcontrol. Replace.

No warning signal

- Vacuum above -0,65 bar? Device o.k..
- Defective vacuum control? Replace.
- Buzzer for signal horn defective? Replace.

Maintenance

Note

Please note that the trades association requires an annual inspection of vacuum lifting devices by a specialist, in accordance with the accident prevent regulations (VbG 9a-prEN 13155:1998). If you do not have a suitable staff member, we offer a maintenance contract for our vacuum lifting devices, which includes annual maintenance including testing and certification. Please contact us for details.

Kappel Flachglastechnik GmbH
Schlachthofstraße 3-5
87700 Memmingen
Phone: (+49) 8331 / 4487
Fax: +49 8331 / 82962

The suction cups

The suction cups must be cleaned occasionally with a clean cloth. Please do not use a solvent (such as gasoline or similar substances). Never treat the suction cups with talc, lubricants, or smoothing agents, as this impairs the adhesion of the suction cups, causing the transported goods to slip from them.

The vacuum lines

The hoses must be inspected occasionally for visible cracks, etc. Replace defective hoses immediately!

Note

- Blue hose connections = vacuum circuit 1
- Black hose connections = vacuum circuit 2

Leak check

A leak test of the two independently operating vacuum circuits must be performed at least once a week. Check the entire vacuum circuit with all suction cups (7) and the hose lines.

To do this, turn the switch to ON. It is also necessary to set all suction cups on a gas-impermeable, flat material (for example, a metal or glass sheet) that can be sucked up. Then switch on the OFF/ON switch. Once the maximum vacuum is reached (normally -0,72 bar in any vacuum circuit), turn the OFF/ON switch to OFF. Read the achieved vacuum from the vacuum gauges and record the value in writing. The indicators of the vacuum gauges are only permitted to change slightly in the next 15 minutes, not more than 5%. If the result of this test is positive, the vacuum lifting device is tight, and you can work with it without risk.

If the test is negative in one or both of the vacuum circuits, you can repair the leak and seal it or replace the leaking material, as described in the Troubleshooting chapter. The leak must be corrected immediately or the porous material replaced.

Caution

Always check the pump and the other elements for operational safety before starting work / commissioning.

Warning

NEVER operate the DSY2-12V **with only one** operative vacuum circuit.

Technical data

Manufacturer:	Kappel Flachglastechnik GmbH
Designation:	Vacuum lifting device (battery-operated)
Type:	DSZ2-12V
Serial number:	_____
Year of manufacture:	_____
Operating instructions:	Art.- no.: KA-DSZ2-12V-N
Manufacturer's address:	Kappel Flachglastechnik GmbH Schlachthofstraße 3-5 87700 Memmingen Phone: 08331/4487 Fax: 08331/82962
After-sales service:	Phone: 08331/4487

Performance data for the DSZ2-12V

Maximum size of the plate material to be transported

Height:	approx. 2000 mm
Width:	approx. 3000 mm

With width extension

Height:	max. 3210 mm
Width:	max. 6000 mm

Frame size

Height:	790 mm
Width:	1400 mm
Depth:	160 mm

Temperature range

Operating temperature	-1 to +35° C (ambient temperature)
Storage temperature	-5 to +50° C (ambient temperature)

<u>Dead weight</u>	75 kg
--------------------	-------

<u>Vacuum storage tank</u> circuit 0.5 liters	1st vacuum circuit 0.5 liters / 2nd vacuum
<u>Hose connection</u>	6 mm

Any information regarding the carrying capacity refer to even surface load.
Furthermore, all suction cups must have solid suction contact with the goods to be transported.

DSZ2-12V delivered with suction caps, type _____

Number of suction cups _____

Lifting capacity, vertical: _____

Lifting capacity, horizontal: _____

Suction cup, type 150 K

Diameter:	330 mm
Carrying capacity on smooth, clean, dry surface with 60% vacuum	
Vertical:	150 kg
Horizontal:	150 kg
Vacuum connection:	9 mm

Two vacuum pumps

Supply voltage:	12V, DC
Nominal current:	approx. 8A

Two batteries

Nominal voltage:	12V, DC
Nominal capacity:	approx. 7A

Mains operation

Mains voltage:	220-240V, AC
Mains frequency:	50/60 Hz

Options for the DSZ2-12V

Six removable width extensions with support suction cups to achieve greater surface stability with larger panes.
(three support suction cups / vacuum circuit)

One lowering cylinder to brake the swivel movement.

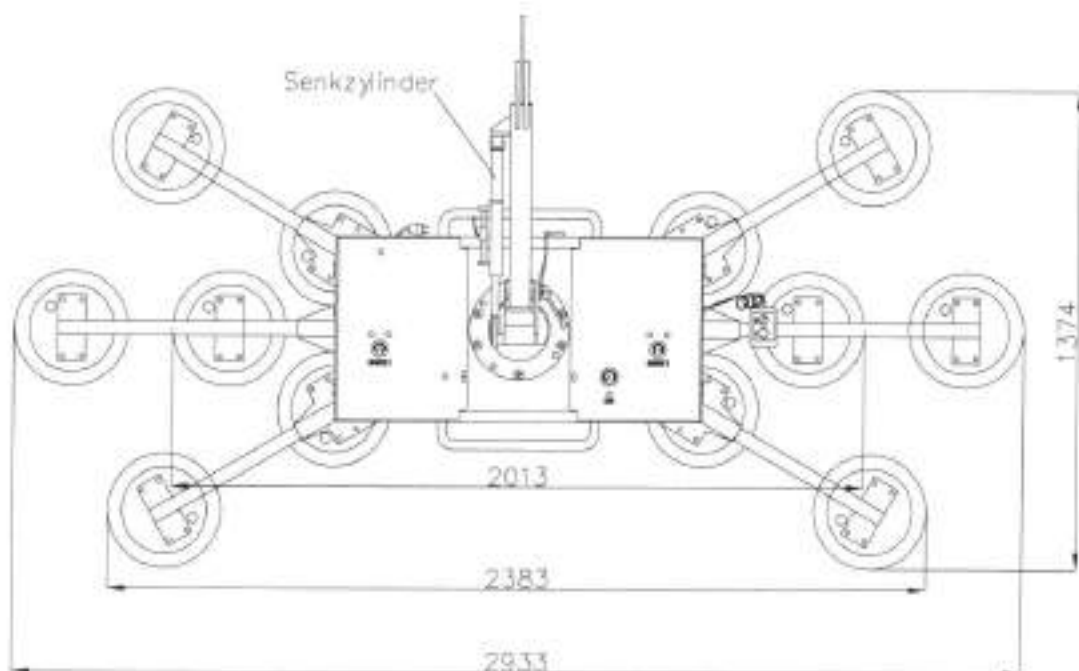
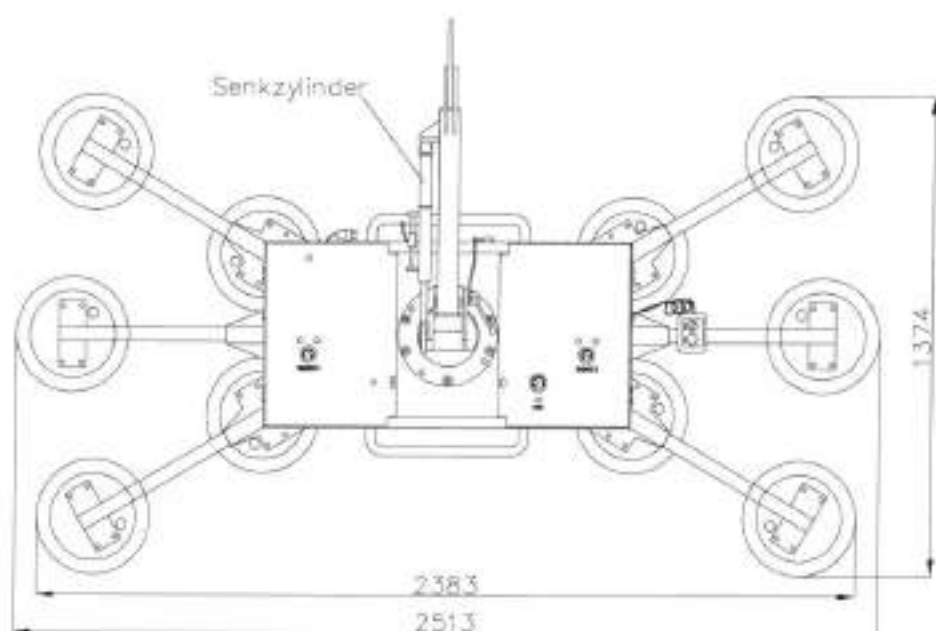

Circuit diagram DSZ2-12V

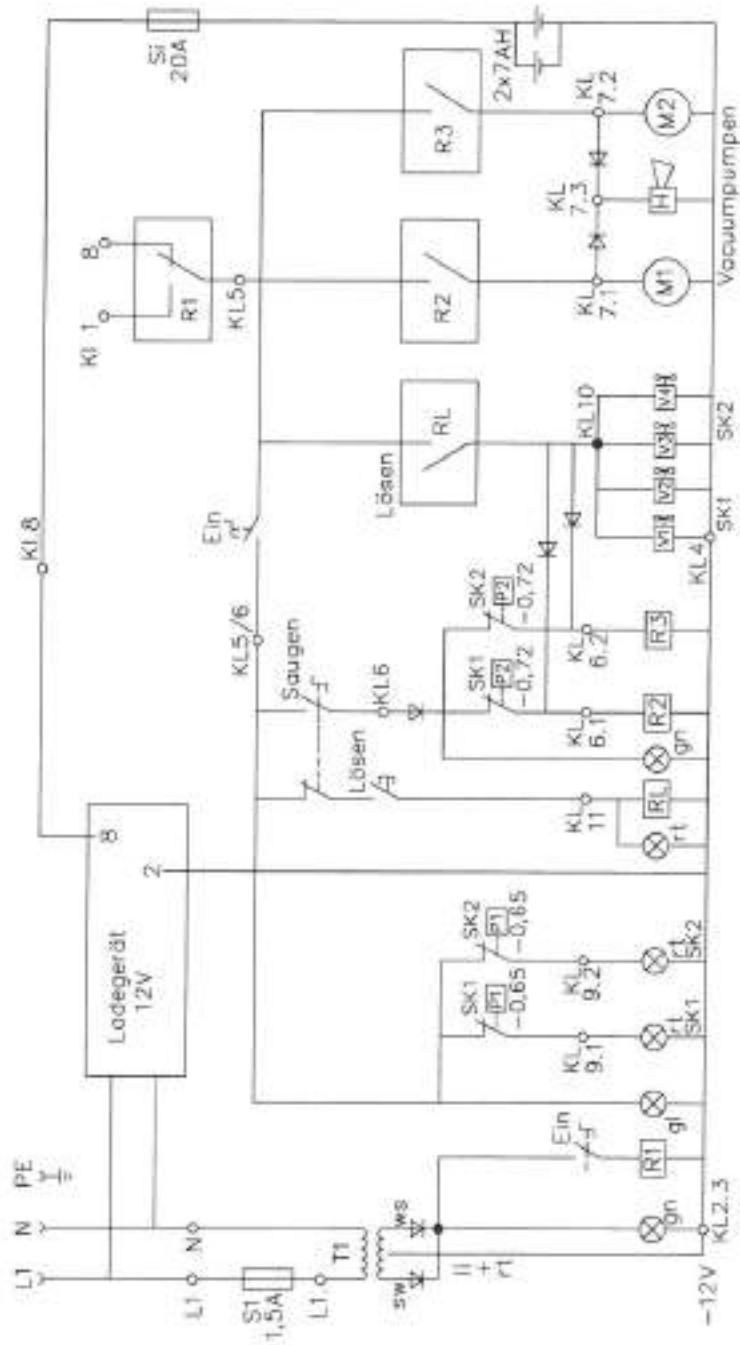

Spare parts list for DSZ2-12V

Position	Order no.	Quantity	Designation
1		1	Suspension eye
2	Mader	2	Vacuum meter 50mm 1/8"
3		1	Charger XS 0.8
4	150K		Suction cups 150 Kappel
5		1	Pressure switch red/green
6	118.068.14	1	Buzzer (horn) 12V DC
7	64590	1	Charge indicator 12 V DC
8		2	LED indicator lamp 12V red
9		3	LED indicator lamp 12V green
10	726060	1	LED indicator lamp 12V yellow
11		1	Fuse 15A
12	0826-02	2	Vacuum pump Dynaflor 12V
13		2	Battery 12V DC 7Ah
14	Mader	4	3/2 Way valve 1/8" 12V/12W
15		4	Micro ball valve 1/8"
16	6.256.540	2	Vacuum control, type 625 (P1)
17	6.256.540	2	Vacuum control, type 625 (P2)
18	SMC	2	Check valve 1/8" 6mm
19	Mada	10	¼" S.S couplings
20		1	Lowering cylinder
21	701271	1	Stainless steel button d=16mm
22		1	RKT Transformer, type RSO860884 235YA
23		1	Rectifier 35A
23		1	ETA fuse 2.5A 106-P10
24		1	Housing XAL D02
25		1	Button, red ZB5 AW343
26		2	Auxiliary switch block ZEN-L1111
27		1	Auxiliary switch block ZEN-1121
28		1	LED module ZAL-VB5
29		1	LED module ZAL-VB4
30		1	Selector switch, yellow ZB5 AK1253
31		1	Coiled cable 500mm 5G 0,75
32		1	Flat fuse switch



Daily Pre-Use Checklist

Vacuum Lifter

Northern (Head Office) Tel: +44 (0)1482 227333

Central Tel: +44 (0)1302 341659

Western Tel: +44 (0)1384 900388

Southern Tel: +44 (0)203 174 0658

www.hird.co.uk

Machine Model: Kappel DSZ2 900kg		Site Name:
Date Week Commencing:	Fleet No:	Address:
Inspected by:		

Daily Pre-use Checks

		M	T	W	T	F	S	S	COMMENTS
1	Are all operators manuals present and readable								
2	Is the Report of Thorough Examination (LOLER) in date								
3	Complete a visual walk around / Inspection for any noticeable defects								
4	Are all safety information decals present and readable								

Check the following components or areas for damage, or missing parts & unauthorised modifications:

5	Is the lifting attachment free from defects and safe to use								
6	Vacuum pads for rips, tears, quality and cleanliness								
7	Vacuum pipes and connections (in particular quick release fittings)								
8	All extension arms are present and free from defects (where applicable)								
9	Make sure all individual pad shut off valves are open (where applicable)								
10	Electrical components, wiring, connectors,								
11	Check input mains voltage corresponds with charger voltage (110v or 240v)								
12	Charger								
13	Check battery has sufficient charge								
14	Are rotation and tilting movements functional								
15	Check handles security								
16	Check remote for any damage or defects (where applicable)								
17	Check operation buttons / switches are working and free from defects								
18	Energise vacuum on non porous surface								
19	Are lights and audible alarms on during vacuum process								
20	Does the vacuum reach sufficient level, before switching off (see gauges)								
21	Does battery gauge illuminate when pump switches off If NO - DO NOT USE								
22	Check Safe Working load of vacuum - is it suitable for the proposed load								
23	Carry out full function test								

Is the machine safe to use? (please circle)	YES	YES	YES	YES	YES	YES	YES	
	NO	NO	NO	NO	NO	NO	NO	
Operator's Initials								

Result of Inspections: List defects or state "No Defects"

Signature:	Name:	Date:
------------	-------	-------