

HIRD
GLASS

www.hird.co.uk

OPERATOR MANUAL

GLASBOY 500

(500KG)



Northern (Head Office)
Tel: +44 (0)1482 227333

Central
Tel: +44 (0)1302 341659

Western
Tel: +44 (0)1384 900388

Southern
Tel: +44 (0)203 174 0658

BEFORE WORK BEGINS WITH THE GLASBOY/BIGFOOT THE PERSON OPERATING THE EQUIPMENT SHOULD BE FAMILIARIZED.

Area of use

The Glasboy/Bigfoot is powered by a hydraulic hand pump and can be used for lifting, lowering and manoeuvring of loads.

Handling and working with the Glasboy/Bigfoot

Place the Glasboy/Bigfoot in front of the object to be lifted

Lifting of loads

Turn the valve screw clockwise until the valve is closed. The load can now be lifted to the required height using the pump handle.

Manoeuvring with loads

The Glasboy/Bigfoot is designed for moving with loads suspended from the hook either directly or via the correct lifting accessory. Care must be taken when moving with a load to ensure there are adequate personnel available to prevent the load from swinging or striking against objects.

Always move the Glasboy/Bigfoot smoothly and avoid sudden movement or changes of direction. Plan the route beforehand. When in position apply the wheel brakes to prevent further movement, in certain circumstances it may be necessary to use additional stopping measures.

Lowering of loads

Turn the valve screw slowly anticlockwise, this controls the lowering speed.

Safety

Spare parts

Only original spare parts are to be used, otherwise this will invalidate any guarantee claims and the safety of the lifts can no longer be assured. Changes and additions, which have not been carried out by us, release us from any responsibility or possible damage claims. In the case of repair or spare parts please contact us.

Before work begins with any Glasboy/Bigfoot the operator must be familiarized with the equipment. Ensure pre-use check list has been read and completed correctly.

Where a vacuum unit is being used, only loads that are dry, clean, free of oil and dust are to be mounted. Thoroughly read the 'Operating Instruction Manual' and safety regulations of vacuum unit.

Never overload the lifting arm in its different load positions.

Never work or walk under raised loads.

GLASSBOY AND BIGFOOT

Danger of Overturning

Do not use the Glasboy/Bigfoot as a ladder.

The ground must be level and uniform.

Always ensure that the castors have full contact with the ground.

Never leave raised loads unattended.

Work is to be ceased with the Glasboy/Bigfoot if wind speed is 22mph – 35kph – 9.7m/s

Do not forget, ANYTHING suspended on the boom, e.g. vacuum lifter, hoist, etc. reduces the load the Glasboy/Bigfoot can lift.

Maintenance

Oil Roller bearings regularly, check securing rings.

Visually check welded joints.

Filling hydraulic cylinder with oil:

- Before filling ensure that lifting arm is in its lowest position;
- Wipe around the filling port with a clean rag;
- Remove screw from the filling port of the hydraulic cylinder;
- Only use fresh hydraulic oil and clean equipment;
- Fill slowly with hydraulic oil;
- Replace the filling port screw and tighten it;
- Test the action of the ram.

Transport position



Glassboy 330 Technical Specifications

Technical Specifications	Capacity	Arm Extension
Position 1	330kg	900mm
Position 2	300kg	1020mm
Position 3	270kg	1140mm
Position 4	250kg	1260mm
Weight (without counterweights)	122kg	
Weight (with counterweights)	408kg	
Counterweights	13	

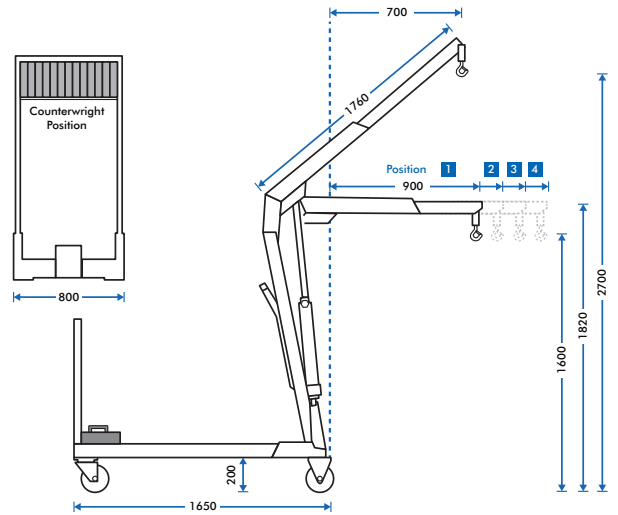

Glassboy 500 Technical Specifications

Technical Specifications	Capacity	Arm Extension
Position 1	500kg	900mm
Position 2	420kg	1020mm
Position 3	370kg	1140mm
Position 4	300kg	1260mm
Weight (without counterweights)	134kg	
Weight (with counterweights)	706kg	
Counterweights	26	

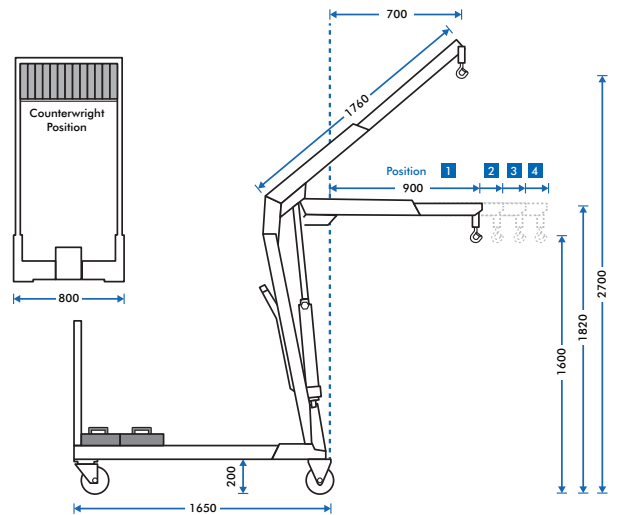

Bigfoot 280 Technical Specifications

Technical Specifications	Capacity	Arm Extension
Position 1	280kg	830mm
Position 2	250kg	950mm
Position 3	220kg	1070mm
Position 4	190kg	1190mm
Weight (without counterweights)	446kg	
Weight (with counterweights)	160kg	
Counterweights	13	
Transport Dimensions (folded)	1650mm (l) 780mm (w) 700(h)	

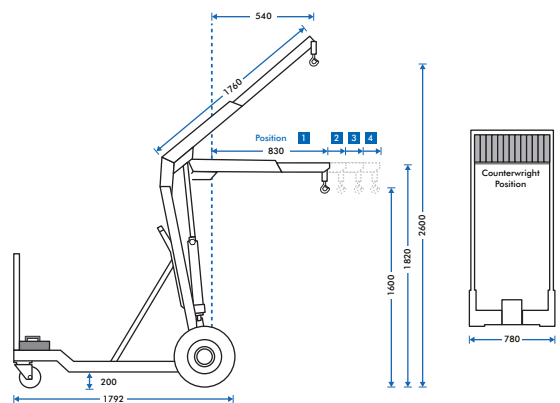

Glassboy 330 Spare Parts List

Pos.	Description
1	Hook
4	Connection
6	Pump
8	Front wheel
10	Back wheel
11	Counterweight
12	Arch
15	Pump holder

The other parts have the same description as the parts of the Glasboy.

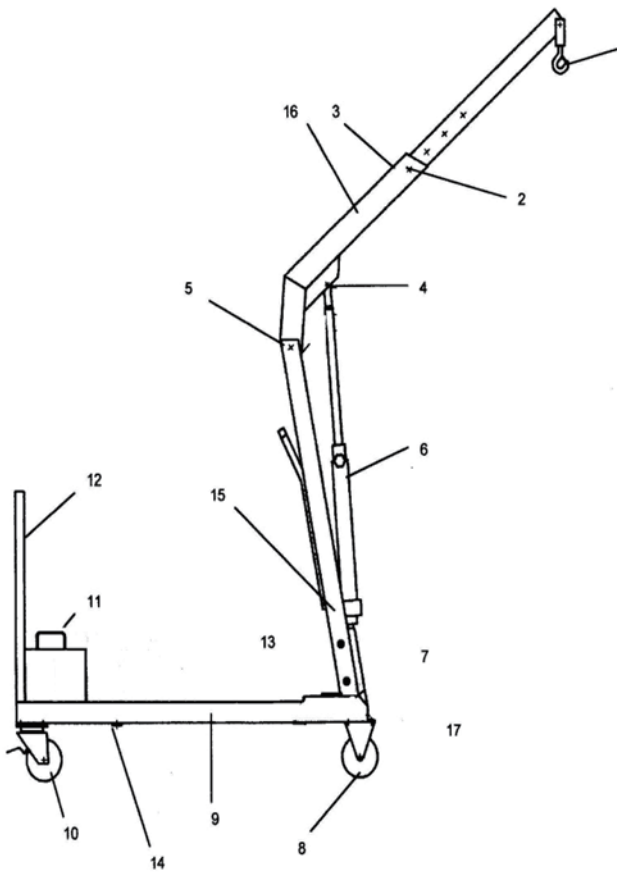



Daily Pre-Use Checklist

Counterbalance Floor Crane

Northern (Head Office) Tel: +44 (0)1482 227333

Central Tel: +44 (0)1302 341659

Western Tel: +44 (0)1384 900388

Southern Tel: +44 (0)203 174 0658

www.hird.co.uk

Machine Model: Glasboy 500		Site Name:
Date Week Commencing:	Fleet No:	Address:
Inspected by:		

Daily Pre-use Checks		M	T	W	T	F	S	S	COMMENTS
1	Are all operators manuals present and readable								
2	Is the Report of Thorough Examination (LOLER) in date								
3	Complete a visual walk around / Inspection for any noticeable defects								
4	Are all safety information decals present and readable								

Check the following components or areas for damage, or missing parts & unauthorised modifications:

5	Cators are free from defects								
6	Footbrake(s) is operational								
7	Chassis is in good condition with no major defects								
8	Nut, bolts & other fasteners								
9	Push handle has no major defects								
10	Counterweights are free from defects								
11	Counterweights are all fitted correctly								
12	Main lifting ram is secure								
13	Boom sections are secure and free from defects								
14	All boom extension pins are present								
15	Hook is in serviceable condition								
16	Check operation of lifting ram (without load)								
17	Lowering mechanism is operational								
18	Carry out full function test								

Is the machine safe to use? (please circle)	YES	YES	YES	YES	YES	YES	YES
	NO	NO	NO	NO	NO	NO	NO

Operator's Initials							
----------------------------	--	--	--	--	--	--	--

Result of Inspections: List defects or state "No Defects"

Signature:	Name:	Date:
-------------------	--------------	--------------